

## Mixing Control Adjustment

The thermostatic blending valve is factory set to provide water mixed at 45°C to the heating manifold.

The mixed water temperature can be adjusted to suit the design flow temperature within the range 35°C to 65°C.

With the boiler firing and the heating circuit balanced; the mixed water flow temperature can be easily adjusted by rotating the control knob of the blending valve as indicated, clockwise to increase the temperature and anticlockwise to reduce it.

To measure the mixed water temperature, use a suitable thermometer, preferably digital, to measure the surface temperature on the pump outlet elbow. Adjust the temperature as specified for the application and site conditions.

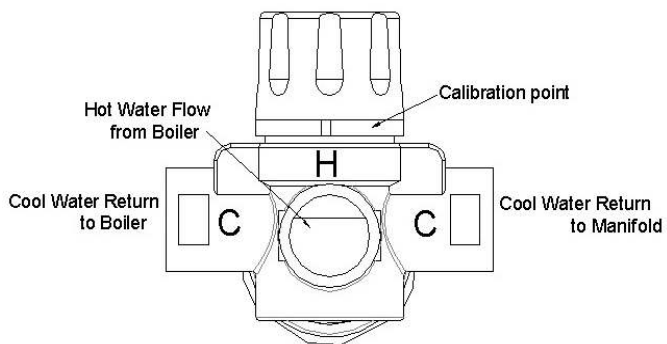

## Introduction

## Installation

The thermostatic blending valve can be easily installed

Using a 54mm A/F spanner slacken the 2 union nuts on the pump and rotate through 180° the blending valve and the pump outlet elbow as shown below.

Re-tighten the union nuts, check the joints for leakage and vent the unit using the air vent on the pump outlet elbow.

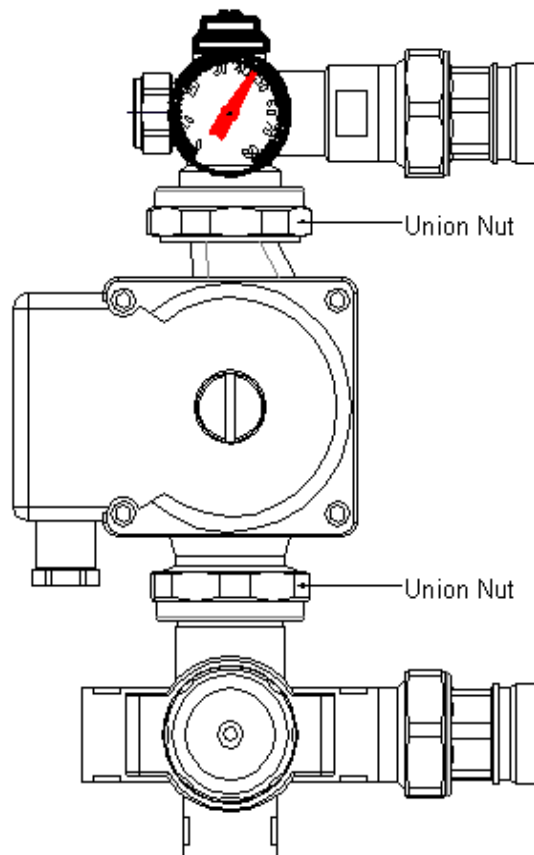

## Dimensions

# Pump Mixer Set

Installation guide

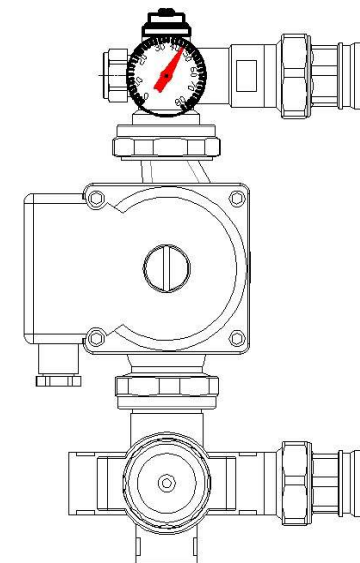

We have endeavoured to make information in this guide as accurate as possible. We cannot accept any responsibility should it be found that the information is inaccurate or incomplete in any respect, or becomes so as a result of further developments or otherwise.

Continue to screw the swivel nuts by hand, a few turns at

The valve works at lower temperatures than radiator systems, with temperatures between 35°C to 65°C depending upon the construction of the floor. The blending valve is the heart of the control system with hot water from the boiler mixed to supply water at the correct temperature back to the underfloor pipework. The supply temperature of the water can be adjusted to suit the construction of the floor.

The thermostic controller is used with flow and return manifolds to control the flow temperature of water to the underfloor heating pipework.

Suitable for up to a 15kW heating load, this compact lightweight underfloor thermostic mixing controller comes complete with a 6m head pump which has been designed for direct connection and is supplied fully assembled in left hand format with G1 male swivel flat seal unions as standard.

Its versatile design and union joint connections provides a simple and quick conversion on site to right hand format if required. Installing the controller to the manifold is simple and quick, requires no additional supporting brackets and so eliminates the need for time consuming drilling and fixing.

**Note:**

The flow and return manifolds must be securely fixed to the wall or cabinet and isolating valves should be installed between the manifolds and the control unit.

**Note:**

If the primary circuit serving the underfloor heating is not fitted with an automatic bypass valve, it is recommended that one is installed across the flow and return pipes, upstream of the mixing control to protect the boiler and improve system efficiency.

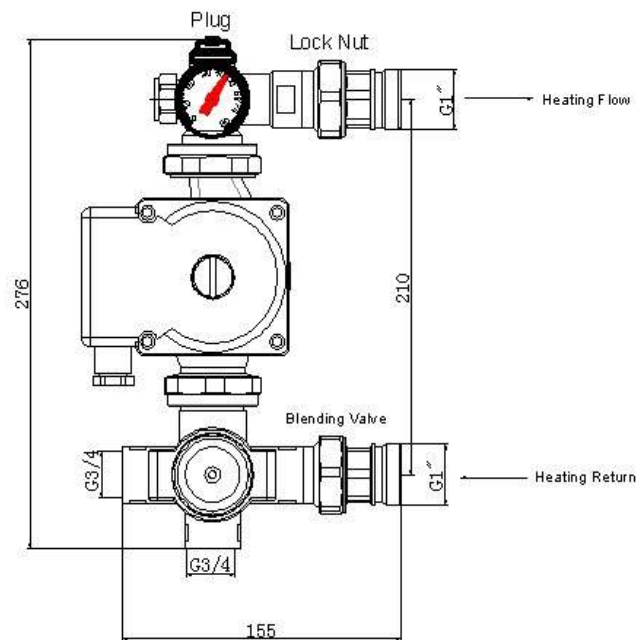

**Installation**

The control unit is supplied pre-assembled for quick connection to the flow and return manifolds and the hot and return water supplies to the boiler.

Insert the fibre gaskets into the female threaded port of the isolating ball valves. To ensure a perfect seal, the mating port should have a facility e.g; a flat face, against which the gasket can be tightened.

Offer the control unit to the ports, locating the bottom (return) flat faced union connection first, then swing the top (flow) union to align with the flow ball valve socket.

Push the control unit fully into the manifold (or ball valve) and connect the swivel nuts to the female thread by hand.

time, turns at time, until fully engaged with the gasket. Ensure that the control unit and manifolds are aligned correctly and securely held to the wall or back of the mounting cabinet by the mounting brackets supplied with the manifolds.

Use an appropriately size spanner on the corresponding end of the ball valve (adjacent to the swivel nut) and using a 36mm A/F spanner tighten the swivel nut to make a water tight joint. Repeat for the second swivel nut joint.

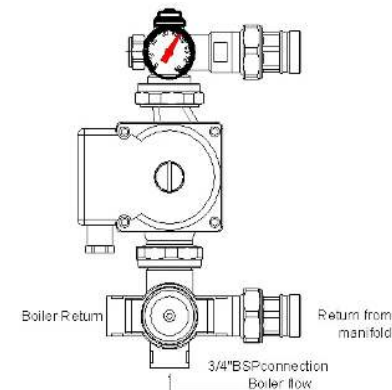

**Wiring**

All electrical wiring should be undertaken by a qualified electrician and must conform to IEE regulations.

**Commissioning**

To protect and prevent damage to the blending valve and other devices in the heating circuit, it is recommended that the connecting pipe work is thoroughly flushed to remove any debris before filling and venting the system.

Close the manifold isolating valves, with the system filled and pressurised, vent the control unit via the air vent on the pump outlet elbow.

Open the manifold isolating valves and other valves and vent via the air vent again.

With the primary pipework to the boiler, the control unit and manifolds both filled and at the correct system operating pressure it is important to check all joints for any leakage.