

Weather-compensated system control

VRC 700f/4

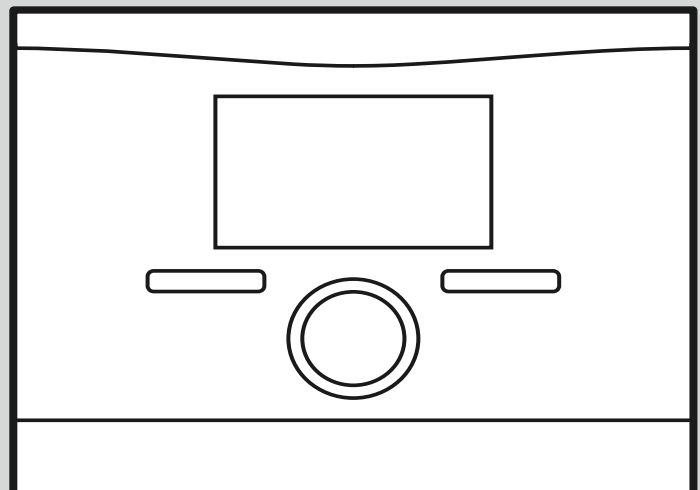

Installation instructions

Contents

1	Safety	4	9	Troubleshooting	23
1.1	Intended use	4	9.1	Troubleshooting measures	23
1.2	General safety information	4	9.2	Maintenance message	23
1.3	Regulations (directives, laws, standards)	4	10	Spare parts	23
2	Notes on the documentation	5	10.1	Procuring spare parts	23
2.1	Observing other applicable documents	5	10.2	Changing the batteries.....	24
2.2	Storing documents.....	5	10.3	Replacing the outdoor temperature sensor	24
2.3	Validity of the instructions	5	10.4	Disposing of the outdoor temperature sensor if defective	24
2.4	Nomenclature	5	11	Decommissioning	24
3	Product description	5	11.1	Decommissioning the heating installation	24
3.1	Data plate	5	12	Recycling and disposal	25
3.2	CE marking	5	13	Customer service	25
4	Set-up	5	14	Technical data	25
4.1	Checking the scope of delivery.....	5	14.1	System control.....	25
4.2	Selecting the lines.....	5	14.2	Radio receiver unit.....	25
4.3	Installing the radio receiver unit on the wall.....	6	14.3	Outdoor temperature sensor	26
4.4	Installing the outdoor temperature sensor	6	Appendix	27	
4.5	Installing the system control	8	A	Setting values for basic system diagram, VR 70 and VR 71	27
5	Electrical installation	9	A.1	Basic system diagram configuration	27
5.1	Polarity.....	9	A.2	Gas-/oil-fired condensing boiler (eBUS)	27
5.2	Connecting the radio receiver unit to the heat generator	9	A.3	Gas-/oil-fired condensing unit (eBUS) and solar hot water support	27
5.3	Connecting the radio receiver unit to the ventilation unit.....	9	A.4	Gas-/oil-fired condensing unit (eBUS) and solar hot water and heating support	27
6	Start-up	9	A.5	aroTHERM or flexoTHERM	28
6.1	Preparatory work for start-up.....	9	A.6	aroTHERM and domestic hot water cylinder downstream of low loss header	28
6.2	Starting up the heating installation	9	A.7	aroTHERM or flexoTHERM and solar hot water support.....	28
6.3	Changing the settings later	10	A.8	aroTHERM or flexoTHERM and solar hot water and heating support	28
7	Operating and display functions	10	A.9	aroTHERM with system separation.....	28
7.1	Resetting to factory setting	10	A.10	aroTHERM with auxiliary heater and system separation	29
7.2	Service information	11	A.11	aroTHERM with system separation and solar hot water support.....	29
7.3	System.....	11	A.12	geoTHERM 3 kW , hot water generation using a gas-fired condensing boiler (eBUS).....	29
7.4	Basic system diagram configuration.....	13	A.13	aroTHERM or flexoTHERM , hot water generation using a gas-fired condensing boiler (eBUS).....	29
7.5	Additional module	14	A.14	aroTHERM with system separation, hot water generation using a gas-fired condensing boiler (eBUS).....	30
7.6	Heat generator 1, heat pump 1, additional module	14	A.15	aroTHERM or flexoTHERM , hot water generation using a heat pump and gas-fired condensing boiler (eBUS).....	30
7.7	HEATING 1	15	A.16	aroTHERM with system separation, hot water generation using a heat pump and gas-fired condensing boiler (eBUS).....	30
7.8	ZONE1	17	A.17	aroTHERM and gas-fired condensing boiler (eBUS), heat pump cascade option	31
7.9	DHW circuit.....	18	B	Overview of the setting options	31
7.10	Buffer cylinder.....	19	B.1	Installer level.....	31
7.11	Solar circuit.....	20	B.2	Functions for the heating circuit.....	34
7.12	Solar cylinder 1	21			
7.13	2nd differential temperature control.....	21			
7.14	Ventilation	22			
7.15	Radio link.....	22			
7.16	Selecting the wiring centre for sensor/actuator test	22			
7.17	Activating the screed-drying function.....	22			
7.18	Changing the code for Installer level	23			
8	Handing over to the end user	23			
8.1	Handing the product over to the end user	23			

C	Connecting the actuators, sensors and sensor assignment for the VR 70 and VR 71	35
C.1	Legend for connecting the actuators and sensors	35
C.2	Connecting the actuators and sensors to VR 70	36
C.3	Connecting the actuators to VR 71	36
C.4	Connecting the sensors to VR 71	36
C.5	VR 70 sensor assignment	36
C.6	VR 71 sensor assignment	37
D	Overview of troubleshooting measures	37
E	Maintenance messages	39
Index	40



1 Safety

1.1 Intended use

In the event of inappropriate or improper use, damage to the product and other property may arise.

The product is intended for using an eBUS interface to control a heating installation with heat generators from the same manufacturer.

The radio control, the radio receiver unit and the wireless outdoor temperature sensor must be installed in a location that receives sufficiently high signal. The radio control is not intended to be portable.

- observance of accompanying operating, installation and maintenance instructions for the product and any other system components
- installing and setting up the product in accordance with the product and system approval
- compliance with all inspection and maintenance conditions listed in the instructions.

Intended use also covers installation in accordance with the IP code.

Any other use that is not specified in these instructions, or use beyond that specified in this document, shall be considered improper use. Any direct commercial or industrial use is also deemed to be improper.

Caution.

Improper use of any kind is prohibited.

1.2 General safety information

1.2.1 Risk caused by inadequate qualifications

The following work must only be carried out by competent persons who are sufficiently qualified to do so:

- Set-up
- Dismantling
- Installation
- Start-up
- Inspection and maintenance
- Repair
- Decommissioning
- ▶ Proceed in accordance with current technology.

1.2.2 Risk of material damage caused by frost

- ▶ Do not install the product in rooms prone to frost.

1.2.3 Danger due to malfunctions

- ▶ Install the system control in a location where it is not covered by furniture, curtains, or other objects.
- ▶ If room temperature modulation is activated, advise the end user that, in the room where the system control is mounted, all the thermostatic radiator valves must be fully open.
- ▶ At lengths of 10 m or more, power supply cables must be laid separately from sensor or bus lines.

1.2.4 Risk of material damage caused by using an unsuitable tool

- ▶ Use the correct tool.

1.3 Regulations (directives, laws, standards)

- ▶ Observe the national regulations, standards, directives, ordinances and laws.



2 Notes on the documentation

2.1 Observing other applicable documents

- ▶ Always observe all the operating and installation instructions included with the system components.

2.2 Storing documents

- ▶ Pass these instructions and all other applicable documents on to the end user.

2.3 Validity of the instructions

These instructions apply only to:

VRC 700f/4 – article number

Great Britain	0020231564
---------------	------------

2.4 Nomenclature

The following terms are used for simplification:

- Heat pump: This refers to all heat pumps
- Hybrid heat pump: This refers to the **VWS 36/4 230 V** and **VWL 35/4 S 230 V** hybrid heat pumps.
- System control: This refers to the **VRC 700f** radio control.
- Remote control: This refers to the **VR 91** wireless remote control.
- Outdoor temperature sensor: This refers to the **VR 20** and **VR 21** wireless outdoor temperature sensors.

3 Product description

3.1 Data plate

The data plate is located on the rear of the system control underneath the unit mounting bracket.

The data plate contains the following information:

Information on the identification plate	Meaning
Serial number	for identification; 7th to 16th digits = product article number
VRC 700f/4	Product designation
V	Operating voltage
mA	Current consumption
	Read the instructions
LR06	Battery type designation
T60	Max. permitted environmental temperature: 0 to 60 °C

3.2 CE marking



The CE marking shows that the products comply with the basic requirements of the applicable directives as stated on the declaration of conformity.

The manufacturer hereby declares that the type of radio equipment that is described in these instructions complies with Directive 2014/53/EU. The complete text for the EU Declaration of Conformity is available at: <http://www.vaillant-group.com/doc/doc-radio-equipment-directive/>.

4 Set-up

Obstacles weaken the reception strength between the radio receiver unit and the system control or outdoor temperature sensor.

4.1 Checking the scope of delivery

Quantity	Contents
1	System control
1	Radio receiver unit with wall base
1	VR 20 outdoor temperature sensor or VR 21 outdoor temperature sensor
1	Fastening material (2 bolts and 2 wall plugs)
4	Batteries, LR06
1	Documentation

- ▶ Check that the scope of delivery is complete and intact.

4.2 Selecting the lines

- ▶ Use standard commercial lines for the wiring.
- ▶ Do not use flexible lines for mains voltage supply lines.
- ▶ Use insulation cables for mains voltage supply lines (e.g. NYM 3 x 1.5).

Line cross-section

eBUS line (extra-low voltage)	≥ 0.75 mm ²
Sensor line (extra low voltage)	≥ 0.75 mm ²

Line length

Sensor lines	≤ 50 m
Bus lines	≤ 125 m

4.3 Installing the radio receiver unit on the wall

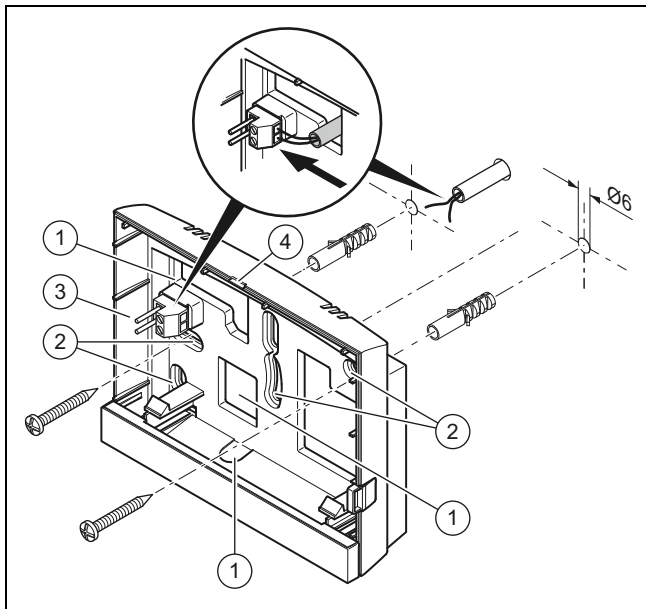

- | | | | |
|---|-------------------------|---|---------------------------------------------|
| 1 | Openings for cable duct | 3 | Pin header with terminals for the eBUS line |
| 2 | Mounting holes | 4 | Opening slot |

1. Screw in the wall base in accordance with the figure.
2. Connect the eBUS line. (→ Page 9)

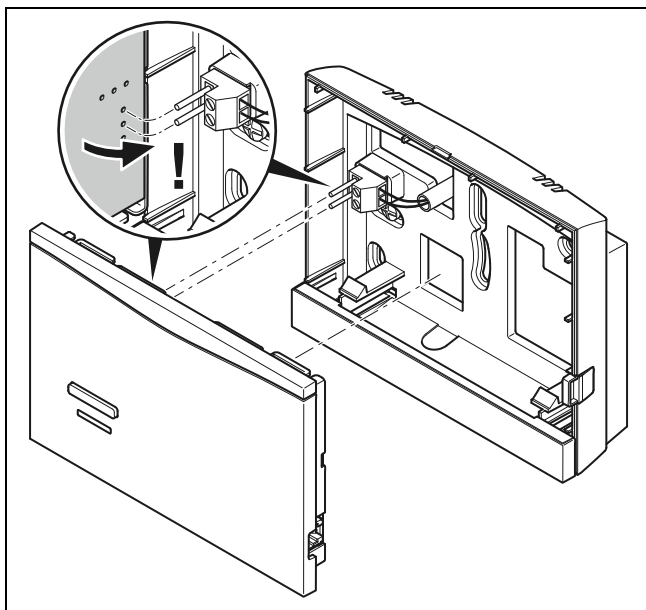

3. Carefully push the radio receiver unit into the wall base.

4.4 Installing the outdoor temperature sensor

4.4.1 Determining the installation site of the outdoor temperature sensor

- Choose an installation site that generally meets the following requirements:
 - not fully protected from wind
 - not particularly draughty
 - not in direct sunlight
 - not affected by heat sources
 - on a north or north-west facing façade
 - in buildings with up to three floors, it should be located two-thirds of the way up the façade

- in buildings with more than three floors, it should be fitted between the second and third floor

4.4.2 Requirements for determining the reception strength of the outdoor temperature sensor

- The set-up and installation of all system components and the radio receiver unit (except for the system control and the outdoor temperature sensor) is complete.
- The power supply for the entire heating installation is switched on.
- The system components are switched on.
- The individual installation assistants for the different system components have been completed successfully.

4.4.3 Determining the reception strength of the outdoor temperature sensor at the chosen installation site

1. Observe all the points listed in "Requirements for determining the reception strength of the outdoor temperature sensor (→ Page 6)".
2. Read the operating concept and the operating example described in the operating instructions for the system control.
3. Stand next to the radio receiver unit.

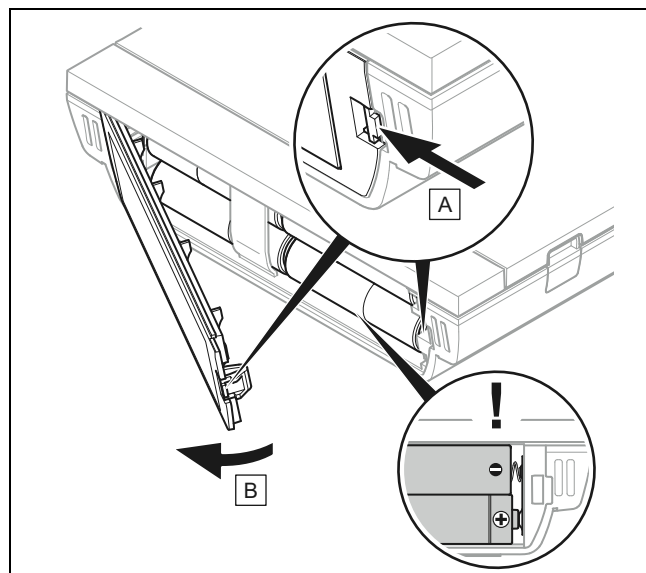

4. Open the system control's battery compartment as shown in the figure.
5. Insert the batteries, making sure that the poles are the right way round.
 - ◀ The installation assistant starts.
6. Close the battery compartment.
7. Select the language.
8. Set the date.
9. Set the time.
 - ◀ The installation assistant switches to the **Control signal strength** function.
10. Take the system control to the chosen installation site for the outdoor temperature sensor.
11. Close all doors and windows behind you on the way to the installation site for the outdoor temperature sensor.
12. If dashes (--) appear in the display instead of the value and the background lighting is off, press one of the selection buttons or turn the rotary knob.

Condition: The background lighting is on, The display is showing dashes (--)

- ▶ Make sure that the power supply is switched on.

Condition: The background lighting is on, The display is showing dashes (--) , The reception strength is < 4

- ▶ Find an installation site for the outdoor temperature sensor that is within the reception range.
- ▶ Find a new installation site for the radio receiver unit that is closer to the outdoor temperature sensor and is within the reception range.

Condition: The background lighting is on, The reception strength is ≥ 4

- ▶ Mark the position on the wall where the reception strength is sufficiently high.

4.4.4 Mounting the wall base to the wall

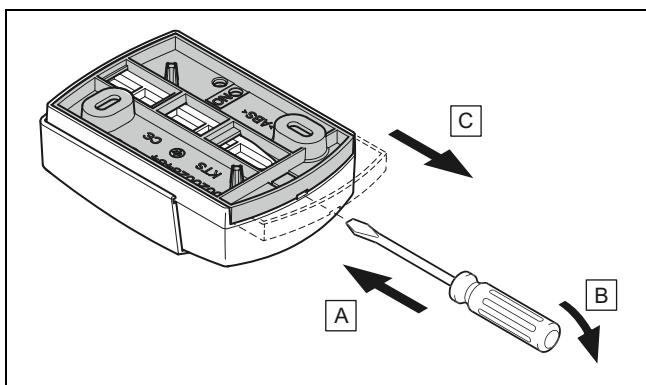

1. Remove the wall base as shown in the figure.

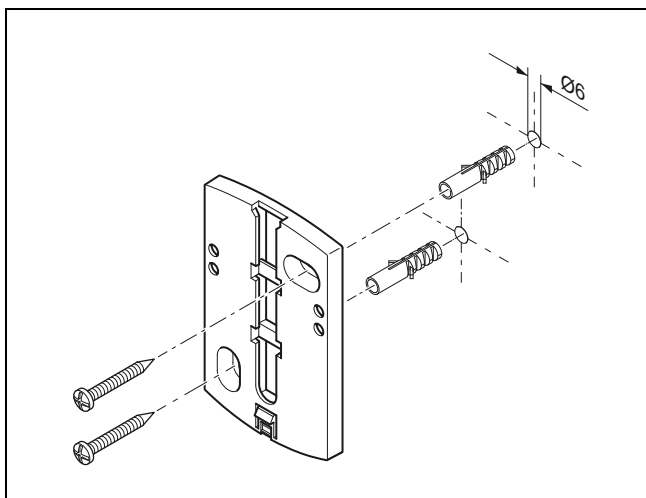

2. Screw in the wall base as shown in the figure.

4.4.5 Starting up and fitting the outdoor temperature sensor

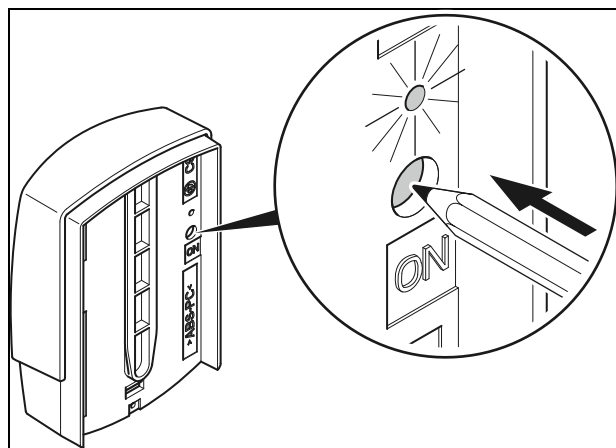

1. Start up the outdoor temperature sensor as shown in the figure.
 - ◁ The LED flashes for a short while.

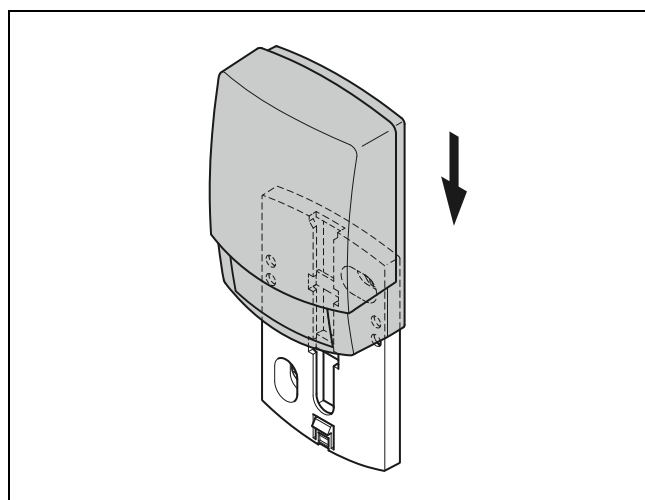

2. Fit the outdoor temperature sensor to the wall base as shown in the figure.

4.4.6 Checking the reception strength of the outdoor temperature sensor

1. Press the **OK** selection button on the system control.
 - ◁ The installation assistant switches to the **OT sensor signal strength** function.

Condition: OT sensor signal strength < 4

- ▶ Find a new installation site for the outdoor temperature sensor where the reception strength is ≥ 5 .
- ▶ Proceed as described in "Determining the reception strength of the outdoor temperature sensor at the chosen installation site (→ Page 6)".

4.5 Installing the system control

Determining the system control's installation site

1. Choose an installation site that meets the following requirements.
 - Interior wall of the main living room
 - Installation height: 1.5 m
 - not in direct sunlight
 - not affected by heat sources

Determining the system control's reception strength at the chosen installation site

2. Press the **Back** selection button.
 - ◀ The installation assistant switches to the **Control signal strength** function.
3. Go to the chosen installation site for the system control.
4. Close all doors behind you on the way to the installation site.
5. If dashes (--) appear in the display instead of the value and the background lighting is off, press one of the selection buttons or turn the rotary knob.

Condition: The background lighting is on, The display is showing dashes (--)

- ▶ Make sure that the power supply is switched on.

Condition: The background lighting is on, The display is showing dashes (--) , The reception strength is < 4

- ▶ Find an installation site for the system control that is within the reception range.

Condition: The background lighting is on, The reception strength is ≥ 4

- ▶ Mark the position on the wall where the reception strength is sufficiently high.

Attaching the unit mounting bracket to the wall

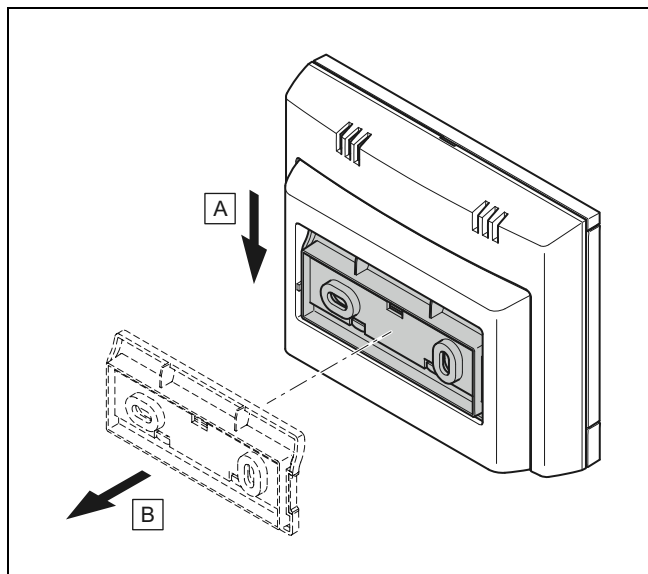

6. Remove the unit mounting bracket from the system control as shown in the figure.

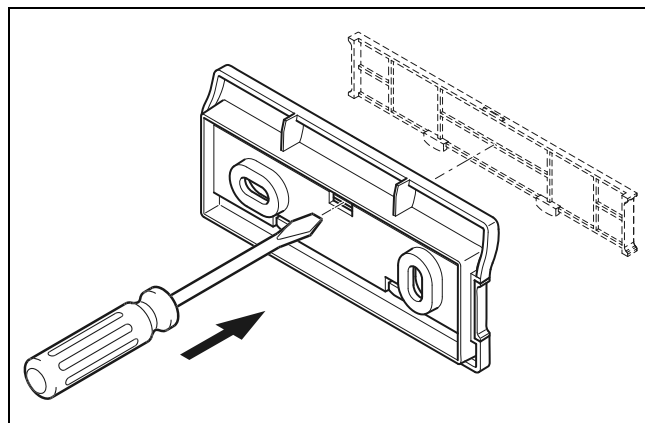

7. Remove the cover on the unit mounting bracket as shown in the figure.

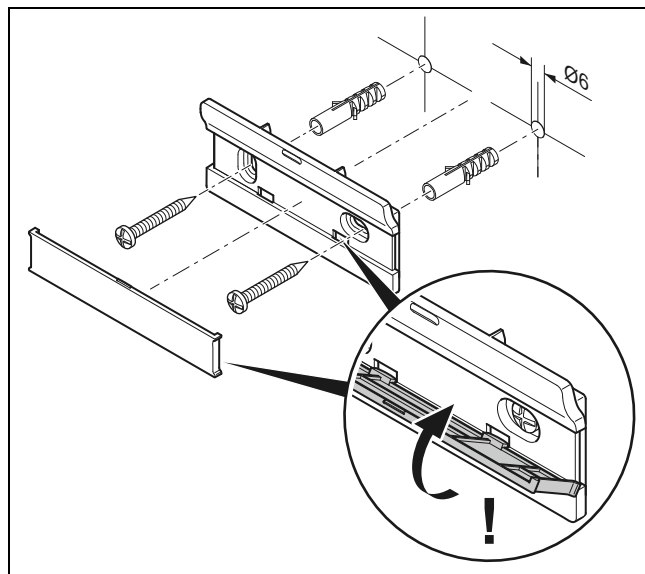

8. Attach the unit mounting bracket including cover as shown in the figure.

Fitting the system control

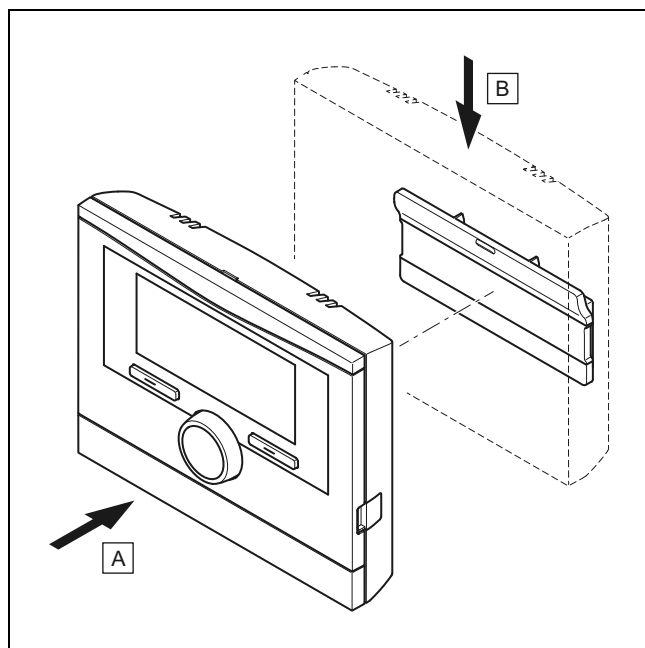

9. Fit the system control to the unit mounting bracket as shown in the figure, making sure that it clicks into place.

5 Electrical installation

Only qualified electricians may carry out the electrical installation.

5.1 Polarity

When connecting the eBUS line, there is no need to pay attention to the polarity. If the connection cables are switched over, communication will not be adversely affected.

5.2 Connecting the radio receiver unit to the heat generator

1. When opening the electronics box in the heat generator, proceed as described in the installation instructions for the heat generator.
2. Connect the eBUS line to the eBUS terminals in the wall base of the radio receiver unit.
3. Connect the eBUS line to the eBUS terminals in the heat generator.

5.3 Connecting the radio receiver unit to the ventilation unit

1. When connecting the radio receiver unit to the ventilation unit, proceed as described in the installation instructions for the ventilation unit.

Condition: Ventilation unit connected to the eBUS without **VR 32**, Ventilation unit without eBUS heat generator

- ▶ Connect the eBUS line to the eBUS terminals in the wall base of the radio receiver unit.
- ▶ Connect the eBUS line to the eBUS terminals on the ventilation unit.

Condition: Ventilation unit connected to the eBUS with **VR 32**, Ventilation unit with up to two eBUS heat generators

- ▶ Connect the eBUS line to the eBUS terminals in the wall base of the radio receiver unit.
- ▶ Connect the eBUS line to the eBUS of the heat generator.
- ▶ Set the address switch for the **VR 32** in the ventilation unit to position 3.

Condition: Ventilation unit connected to the eBUS with **VR 32**, Ventilation unit with more than two eBUS heat generators

- ▶ Connect the eBUS line to the eBUS terminals in the wall base of the radio receiver unit.
- ▶ Connect the eBUS line to the common eBUS on the heat generator.
- ▶ Determine the highest possible position on the address switch of the **VR 32** for the connected heat generator.
- ▶ Set the address switch of the **VR 32** in the ventilation unit to the second highest position.

6 Start-up

6.1 Preparatory work for start-up

All the following preparatory work for starting up the heating installation has been carried out:

- The system control, radio receiver unit and outdoor temperature sensor have been installed and wired.
- The reception strength of the system control and outdoor temperature sensor is ≥ 4 .
- The installation assistant is at the **Have the installation assistants for all system components finished? Press OK to confirm** query.

6.2 Starting up the heating installation

The system control's installation assistant takes you through a list of functions. For each function, you should choose the set value that is best suited to the heating installation being installed.

You must not alter the settings of the functions listed below. The installation assistant will configure these functions according to the values you enter.

6.2.1 Have the installation assistants for all system components finished? Press OK to confirm

You have the option to start up system components that have not yet been started up. Until a system component is started up, the system control does not detect this system component and cannot communicate with this system component.

6.2.2 Searching for eBUS components ...please wait...

The system control searches for system components that communicate via eBUS. The system components that are detected by the system control appear under **Components found**. The system control does not show all system components that are connected to eBUS.

6.2.3 Heating curve

In heating installations with a heat pump, the heat curve for all heating circuits is 0.6.

In all mixed heating circuits with boilers, the heat curve is 0.6.

In all direct heating circuits with boilers, the heat curve is 1.2.
Setting the heating curve (→ Page 16)

6.2.4 Domestic hot water

In heating installations with heat pumps, the desired temperature of the domestic hot water is 55 °C.

In heating installations with heat generators, the desired temperature of the domestic hot water is 60 °C.

Setting the target cylinder temperature (domestic hot water) (→ Page 18)

6.2.5 Zone assignment

The installation assistant assigns zones to the system control and the connected remote controls.

Examples of zone assignment:

No remote control: The system control is always assigned Zone 1.

One remote control: The remote control is assigned Zone 1, the system control is assigned Zone 2.

Two remote controls: Remote control 1 is assigned Zone 1, remote control 2 is assigned Zone 2 and the system control is assigned Zone 3.

The system control is always assigned the next highest zone after the remote controls.

Assigning a zone (→ Page 18)

6.2.6 Config.: VR70 addr. 1

The installation assistant has configured the inputs and outputs of the **VR 70**.

Configuring the inputs and outputs of the **VR 70** (→ Page 13)

6.2.7 Config.: VR71

The installation assistant has configured the inputs and outputs of the **VR 71**.

Configuring the inputs and outputs of the **VR 71** (→ Page 13)

6.2.8 Zone activated

The installation assistant has activated the relevant zones and deactivated the zones that are not required.

Deactivating the zone (→ Page 17)

6.2.9 Type of circuit

The installation assistant specifies which function (inactive or heating) the heating circuits are given. If you require a different setting for one of the heating circuits, you will need to change the function of this heating circuit later. You must check whether the automatic zone assignments are correct.

Setting **Type of circuit** (→ Page 15)

6.2.10 Checking the actuators and sensors

If the **VR 70** or **VR 71** is installed, a list of the actuators and sensors that you can check appears at the end of the configuration.

There can be different entries behind the sensors.

- **OK**: The system control has detected a sensor.
- **??**: The system control is expecting a sensor that has not been installed.
- **--**: The sensor is not installed.
- **(Blank)**: The system control is unable to check whether the sensor is installed correctly.
- **On**: The input at the terminals for the heat demand is open.
- **Off**: The input at the terminals for the heat demand has short-circuited.

6.2.11 Completing the installation assistant

Once you have gone through the installation assistant, **Inst.assist. finished. Continue with:** appears on the display

System configuration: The installation assistant switches to the system configuration for the installer level, in which you can further optimise the heating installation.

System start: The installation assistant switches to the basic display and the heating installation works with the values you have set.

Sensor/actuator test: The installation assistant switches to the sensor/actuator test function. You can test the sensors and actuators here; "Selecting the wiring centre for the sensor/actuator test (→ Page 22)".

6.3 Changing the settings later

All settings that you have made via the installation assistant can be changed again at a later date via the operator or installer operating level.

Installer level (→ Page 31)

Operating levels (→ Operating instructions, Appendix A.2)

7 Operating and display functions



Note

The functions described in this section are not available for all system configurations.

The system control has a level for the end user and a level for the competent person.

The setting and read-out options for the end user, the operating concept and an operating example are described in the operating instructions for the system control.

The setting and read-out options for the competent person can be found via **Menu** → **Installer level Enter code**.

If you do not know the code, you can clear the code using the factory setting (→ Page 10) function. All the set values will be lost if you do this.

Installer level (→ Page 31)

The path details given at the start of each function description indicate how you reach this function in the menu structure. The square brackets contain the level of detail to which the function belongs.

The description of the functions for **HEATING 1, ZONE1, Heat pump 1, Heat generator 1** and **Solar cylinder 1** applies representatively for all existing heating circuits, zones, heat pumps, heat generators and solar cylinders. If a function applies only for certain heating circuits, zones, heat pumps, heat generators and solar cylinders, this is noted for that function.

7.1 Resetting to factory setting

You can use this function to reset all the set values or just the times in the time programmes.

You can find a description of the **Default setting** function in the operating instructions.

The communication link between the system control and the radio receiver unit must not be broken or interrupted.

- Selecting **Menu** → **Basic settings** → **Default setting** takes you to the end user level for the function.
- You can access the **Reset to default setting?** function directly by activating the system control using the rotary knob or one of the selection buttons and then pressing and holding both selection buttons at the same time for at least 10 seconds.

7.2 Service information

7.2.1 Entering contact details

Menu → Installer level → Service information → Enter contact details

- You can enter your contact details (**Installer** and **Phone number**) in the system control.
- As soon as the date of the next maintenance appointment is reached, the end user can view the data in the display.

7.2.2 Entering the service date

Menu → Installer level → Service information → Service date

- In the system control, you can save a date (day, month, year) for the next regular maintenance service.

When the date for a service appointment is reached, a maintenance message is displayed in the basic display.

7.3 System

7.3.1 Reading the fault status

Menu → Installer level → System configuration → [System ----] → Fault status

- This function allows you to read the status of the heating installation. If there is no fault present, the **No fault** message appears. If there is a fault, then **Fault list** appears as a status. If you press the right-hand selection button, the fault messages (→ Page 23) will be displayed.

7.3.2 Reading the water pressure of the heating installation

Menu → Installer level → System configuration → [System ----] → Water pressure

- You can use this function to read the water pressure of the heating installation.

7.3.3 Reading the system status

Menu → Installer level → System configuration → [System ----] → System status

- You can use this function to read the heating installation's operating mode.

Standby: The heating installation does not report any heat demand.

Heat. mode: The heating installation is in heating mode for the heating circuits.

Cooling: The heating installation is in cooling mode.

DHW: The heating installation is in heating mode for the domestic hot water in the cylinder.

7.3.4 Setting the frost protection delay

Menu → Installer level → System configuration → [System ----] → Frost protect. delay

- You can use this function to delay activation of the frost protection function by setting a delay time.

7.3.5 Setting the temperature threshold for constant heating

Menu → Installer level → System configuration → [System ----] → OT constant heating

- If the outdoor temperature is lower than or equal to the defined temperature value, the system control regulates the heating circuit with the set day temperature and heating curve, even outside of the time period.

AT ≤ set temperature value: No night set-back or total shut-down

7.3.6 Reading the software version

Menu → Installer level → System configuration → [System ----] → Control modules

- You can use this function to read the software versions of the display, the heat generator and the wiring centres.

7.3.7 Activating the adaptive heating curve

Menu → Installer level → System configuration → [System ----] → Adaptive heat. curve

- You can use this function to activate an automatic heating curve.

If you have activated this function using **Yes**, the system control automatically adjusts the heat curve. The automatic adjustment of the heating curve is performed in small steps. Use the **Heating curve** function to adapt the heating curve to the building so that the **Adaptive heat. curve** function has to carry out the fine adjustment.

The prerequisite for this is:

- The system control is installed in the living room.
- Any remote control unit that is present is installed in the living room
- In the **Zone assignment** function, the system control or, if required, the remote control unit is assigned to the correct zone.
- The **Thermost.** or **Temp. mod.** value is selected for the **Room temp. mod.** function.

7.3.8 Configuring the heating circuit

Menu → Installer level → System configuration → [System ----] → Configure heat. circ.

- You can use this function to define the zones on which you want the settings for the operating mode and desired temperature from the operator level to take effect.

Example: Two zones are connected and you set **ZONE1**. For both zones, use the left-hand selection button **Menu** → **Basic settings** → **Operating mode** to activate the **Heating** → **Auto** operating mode. If the operator now uses the right-hand selection button **Op. mode** to change the operating mode to **Day**, the operating mode is changed only for **ZONE1**. The **Auto** operating mode remains in place for **ZONE2**.

7.3.9 Activating automatic cooling

Menu → Installer level → System configuration → [System ----] → Automatic cooling

- Use this function to activate or deactivate automatic cooling.

If a heat pump is connected and the **Automatic cooling** function has been activated, the system control automatically switches between heating mode and cooling mode.

7.3.10 Setting the cooling start temperature

Menu → Installer level → System configuration → [System ----] → Start OT cooling

- You can use this function to set the temperature threshold from which cooling starts. If the outdoor temperature is greater than the temperature threshold set, the system control ends cooling mode.

Activating **Cooling possible** (→ Page 17)

7.3.11 Activating Source regeneration

Menu → **Installer level** → **System configuration** → [**System ----**] → **Source regeneration**

- If the **Automatic cooling** function is activated, you can use the **Source regeneration** function.

When the **Days away from home scheduling** function is activated, the system control switches the heating and cooling off. If you also activate the **Source regeneration** function, the system control switches the cooling back on and ensures that the heat from the living room is returned to the ground via the heat pump.

7.3.12 Read current room air humidity

Menu → **Installer level** → **System configuration** → [**System ----**] → **Current room air hum.**

- You can use this function to read the current room air humidity. The room air humidity sensor is installed in the system control.

The function is activated only if the system control is installed in the living room.

7.3.13 Reading the current dew point

Menu → **Installer level** → **System configuration** → [**System ----**] → **Current dew point**

- You can use this function to read the current dew point.

The current dew point is calculated from the current room temperature and room air humidity. The system control obtains the values for calculating the current dew point from the room temperature sensor and room air humidity sensor.

To do this, the system control must be installed in the living room and assigned to a zone. The thermostat function must be activated.

7.3.14 Defining the hybrid manager

Menu → **Installer level** → **System configuration** → [**System ----**] → **Hybrid manager**

- You can use this function to determine the hybrid manager with which the heating installation should be controlled.

The hybrid heat pump always works with the **triVAI** function, meaning that the **Hybrid manager** function does not appear in the display.

triVAI: The price-oriented hybrid manager picks the heat generator on the basis of the tariffs set in relation to the heat demand.

Biv. point: The bivalence point hybrid manager picks the heat generator on the basis of the outdoor temperature.

7.3.15 Setting the heating bivalence point

Menu → **Installer level** → **System configuration** → [**System ----**] → **Heat. bivalence point**

- If the bivalence point is selected for the **Hybrid manager** function, you can then use the **Heat. bivalence point** function.

When outdoor temperatures are low, a back-up boiler helps the heat pump to fulfil the heat demand. You can use this function to set the outdoor temperature above which the back-up boiler remains switched off.

7.3.16 Setting the domestic hot water bivalence point

Menu → **Installer level** → **System configuration** → [**System ----**] → **DHW bivalence point**

- When outdoor temperatures are low, a back-up boiler helps the heat pump to fulfil the heat demand for domestic hot water generation. You can use this function to set the outdoor temperature below which the back-up boiler is enabled.

Irrespective of the affected setting, the back-up boiler for the anti-legionella function is activated.

7.3.17 Setting the alternative point

Menu → **Installer level** → **System configuration** → [**System ----**] → **Alternative point**

- If the bivalence point is selected for the **Hybrid manager** function, you can then use the **Alternative point** function.

The function represents the alternative point. When the outdoor temperature lies below the set temperature value, the system control always switches the heat pump off and the back-up boiler fulfils the heat demand in heating mode.

7.3.18 Setting the temperature when the heat pump fails

Menu → **Installer level** → **System configuration** → [**System ----**] → **T. emergency mode**

- If a heat pump is connected, you can use the **T. emergency mode** function.

If the heat pump fails, the back-up boiler fulfils the heat demand. To avoid higher heating costs due to the back-up boiler, set a low flow temperature.

The end user notices a heat loss and recognises that there is a problem with the heat pump. In addition, the message **Restricted operation/ comfort protection** appears in the display. If the end user releases the back-up boiler to fulfil the heat demand, the system control overrides the set temperature for limp home mode.

You cannot use this function with the hybrid heat pump and it therefore does not appear in the selection list.

7.3.19 Defining the boiler type

Menu → **Installer level** → **System configuration** → [**System ----**] → **Auxiliary heater type**

- If the **triVAI** entry is selected for the **Hybrid manager** function, you can then use the **Auxiliary heater type** function.

This function allows you to select the type of heat generator that is installed in the heating installation in addition to the heat pump.

To ensure that the heat pump and additional heat generator can work effectively and in coordination, you must select the applicable heat generator. If the heat generator setting is incorrect, this may lead to increased costs for the end user.

7.3.20 Deactivating units at the request of the energy supply company

Menu → Installer level → System configuration → [System ----] → Energy supplier

- The energy supply company can use this function to send a deactivation signal.

The deactivation signal relates to the heat pump, the back-up boiler and the heating installation's heating and cooling functions. You can specify which units and functions are deactivated by the system control. The units and functions specified are deactivated until the energy supply company cancels the deactivation signal.

The heat generator ignores the deactivation signal as soon as the heat generator is in frost protection mode.

7.3.21 Selecting the type of back-up boiler support

Menu → Installer level → System configuration → [System ----] → Auxiliary heater for

- You can use this function to specify whether the back-up boiler should support the heat pump for domestic hot water, heating or not at all.
- **DHW:** The back-up boiler supports the heat pump during domestic hot water generation.
The back-up boiler is activated for frost protection or de-icing the heat pump.
- **Heating:** The back-up boiler supports the heat pump during heating.
The back-up boiler is activated for the anti-legionella function.
- **DHW+heat.:** The back-up boiler supports the heat pump during domestic hot water generation and heating.
- **Inactive:** The back-up boiler does not support the heat pump.
The back-up boiler is activated for the anti-legionella function, frost protection or de-icing.

If the back-up boiler is inactive, the heating installation cannot guarantee comfort.

You cannot use this function with the hybrid heat pump and it therefore does not appear in the selection list.

7.3.22 Reading the system flow temperature

Menu → Installer level → System configuration → [System ----] → System flow temp.

- You can use this function to read the current temperature of the low loss header, for example.

7.3.23 Setting the offset for the buffer cylinder

Menu → Installer level → System configuration → [System ----] → Buff. cyl. offs.

- If a heat pump is connected, you can use this function to set an offset value (K) for the buffer cylinder for the heating circuit.

The buffer cylinder is charged to the flow temperature + the set offset value when the **PV** entry is activated for the **Multi-funct. Input** function.

7.3.24 Activating the actuation sequence for the cascade

Menu → Installer level → System configuration → [System ----] → Actuation reversal

- If the heating installation contains a cascade, you can use the **Actuation reversal** function.
- **Off:** The system control always actuates the heat generators in the sequence 1, 2, 3, etc.
- **On:** This function is used to ensure that the heat generators are used evenly. Once a day, the system control sorts the heat generators based on their actuation time. The back-up heater is excluded from this sorting.

7.3.25 Reading the actuation sequence for the cascade

Menu → Installer level → System configuration → [System ----] → Actuation sequence

- You can use this function to read the sequence in which the system control actuates the heat generators. The back-up heater is not affected by this actuation sequence and is therefore not listed.

7.4 Basic system diagram configuration

Each heating installation is based on a system diagram with corresponding connection diagram. A separate basic diagram book contains the basic system diagrams and the corresponding wiring diagrams with explanations.

7.4.1 Defining the basic system diagram

Menu → Installer level → System configuration [System diagram configuration ----] → System diagram

- You use this function to define the basic system diagram in the system control.

The basic diagram book contains basic system diagrams that are suitable for the heating installation that is installed. The basic system diagrams are divided into groups. If you have found a suitable basic system diagram, you must enter the group number in the **System diagram** function.

7.4.2 Configuring the inputs and outputs of the VR 71

Menu → Installer level → System configuration [System diagram configuration ----] → Config.: VR71

- You can use this function to configure which inputs and outputs you can use and which functions the inputs and outputs have.

Each configuration has a unique setting value, which you need to enter in the **Config.: VR71** function. You can find the set value and the terminal assignment for the selected basic system diagram in the basic diagram book.

Connecting the sensors to **VR 71** (→ Page 36)

Connecting the actuators to **VR 71** (→ Page 36)

7.4.3 Configuring the inputs and outputs of the VR 70

Menu → Installer level → System configuration [System diagram configuration ----] → Config.: VR70 addr. 1

- You can use this function to configure which inputs and outputs you can use and which functions the inputs and outputs have.

Each configuration has a unique set value, which you need to enter in the **Config.: VR70 addr. 1** function. You can find the set value and the terminal assignment for the selected basic system diagram in the basic diagram book.

Connecting the actuators and sensors to **VR 70** (→ Page 36)

7.4.4 Configuring the VR 70's multi-function output

Menu → **Installer level** → **System configuration** [**System diagram configuration** ----] → **MA VR70, addr. 1**

- You can use this function to set which functions are to be assigned to the multi-function output.

Connecting the actuators and sensors to **VR 70** (→ Page 36)

If you have set configuration 3 (**Config.: VR70 addr. 1**) for the **VR 70**, you cannot set **Charg.pump** or **Leg. pump**.

The **MA VR70, addr. 1** function does not appear on the display if the functions of the multi-function output have been defined by the system configuration.

7.4.5 Configuring the VR 71's multi-function output

Menu → **Installer level** → **System configuration** [**System diagram configuration** ----] → **MA VR71**

- You can use this function to set which functions are to be assigned to the multi-function output.

Connecting the sensors to **VR 71** (→ Page 36)

Connecting the actuators to **VR 71** (→ Page 36)

If you have set configuration 3 (**Config.: VR71**) for the **VR 71**, you cannot set **TD con.**. For configuration 6, you cannot set **Charg.pump**, **Leg. pump** or **TD con.**.

The **MA VR71** function does not appear in the display if the functions of the multi-function output have been set by the system configuration.

7.5 Additional module

7.5.1 Configuring the multi-function output

Menu → **Installer level** → **System configuration** [**Additional module** ----] → **Multi-funct. output 2**

- You can use the multi-function output 2 to control the circulation pump, dehumidifier or anti-legionella pump.

Depending on the system diagram specified, multi-function output 2 is specified with a single function, or you can set a function from a selection of two or three.

7.5.2 Setting the auxiliary heater output

Menu → **Installer level** → **System configuration** [**Additional module** ----] → **Aux. heater output**

- If you have connected an **aroTHERM**, you can use this function **Aux. heater output**. You can use this function to set the level (max. output) at which the auxiliary heater should work when heat is required.

You can operate the auxiliary heater at three different levels (outputs).

7.5.3 Configuring the multi-function input

Menu → **Installer level** → **System configuration** [**Additional module** ----] → **Multi-funct. Input**

- If a heat pump is connected, you can use the **Multi-funct. Input** function. The system control requests the heat pump's input for this purpose.
- **aroTHERM** input: ME of the VWZ-AI additional module

- **flexoTHERM** input: X41, terminal in the functional drawing

If there is a signal at the input of the heat pump, the following functionalities are possible.

Not conn.: The system control does not activate any functions. The system control ignores the signal present.

Circ. boost: The end user has pressed the circulation button. The system control activates the circulation pump for a short time period.

PV: The connected photovoltaic installation generates surplus current, which is intended to be used for the heating installation. The system control activates the **Cylinder boost** function once. If the signal remains at the input, the system control activates the charging of the buffer cylinder in the heating circuit. This means that the buffer cylinder is charged to the flow temperature and Setting the offset for the buffer cylinder (→ Page 13) until the signal at the input of the heat pump falls away again.

7.6 Heat generator 1, heat pump 1, additional module

7.6.1 Reading the status

Menu → **Installer level** → **System configuration** [**Heat generator 1** ----] → **Status**

Menu → **Installer level** → **System configuration** [**Heat pump 1** ----] → **Status**

Menu → **Installer level** → **System configuration** [**Additional module** ----] → **Status**

- You can use this function to read which heat demand the system control reports to the heat generator, the heat pump or the additional module for the heat pump.

Standby: The system control does not report any heat demand.

Heat. mode: The system control reports a heat demand for the heating mode.

Cooling: The system control reports a heat demand for the cooling mode.

DHW: The system control reports a heat demand for domestic hot water generation.

7.6.2 Reading the current flow temperature

Menu → **Installer level** → **System configuration** [**Heat generator 1** ----] → **Current flow temp.**

Menu → **Installer level** → **System configuration** [**Heat generator 1** ----] → **Current flow temp.**

Menu → **Installer level** → **System configuration** [**Additional module** ----] → **Current flow temp.**

- You can use this function to read the current actual flow temperature of the heat generator, the heat pump or the heat pump's additional module.

7.7 HEATING 1

You can use the heating circuit for various functions (heating circuit, pool circuit, fixed value circuit, etc.). The display only shows the functions that you require when using the heating circuit. You can use the overview to see which functions you can set or read for your configuration.

Functions for the heating circuit (→ Page 34)

7.7.1 Setting Type of circuit

Menu → **Installer level** → **System configuration** → [HEATING1 ----] → **Type of circuit**

- You can use this function to define the functions that the heating circuit is to have.

The first heating circuit in the heating installation has the default setting **Heating**. All other heating circuits have the default setting **Inactive**, which you may have to activate.

Inactive: The heating circuit is not being used.

Heating: The heating circuit is being used to heat and is weather-compensated. Depending on the basic system diagram, the heating circuit may be a mixing circuit or a direct circuit.

Pool: The heating circuit is being used as a pool circuit. You can connect the external pool controller to the DEM1 to DEMx input on the **VR 70** or **VR 71**. If the terminals at the input have short-circuited, there is no heat demand. If the terminals at the input are open, there is a heat demand.

Fixed val.: The heating circuit is maintained at two fixed target flow temperatures. The heating circuit can be switched between two target flow temperatures.

Ret.fl.incr.: The heating circuit is used for the increase in return flow. The increase in return flow is used to protect against corrosion in the floor-standing boiler as a result of falling below the dew point for an extended period.

DHW: The heating circuit is being used as a hot water circuit for an additional cylinder.

Depending on the **Type of circuit** that is selected, only the required functions appear in the display.

7.7.2 Reading the status of the heating circuit

Menu → **Installer level** → **System configuration** → [HEATING1 ----] → **Status**

- You can use this function to read which operating mode the heating circuit is in.

off: The heating circuit does not report any heat demand.

Heat. mode: The heating circuit is in heating mode.

Cooling: The heating circuit is in cooling mode.

DHW: The heating circuit is in heating mode for the domestic hot water in the cylinder.

7.7.3 Reading the heating circuit's target flow temperature

Menu → **Installer level** → **System configuration** → [HEATING1 ----] → **Target flow temp.**

- You can use this function to read the target flow temperature for the heating circuit.

7.7.4 Reading the target flow temperature of the pool circuit

Menu → **Installer level** → **System configuration** → [HEATING1 ----] → **Target flow temp. pool**

- You can use this function to read the target flow temperature of the pool circuit.

7.7.5 Setting the day target flow temperature for the pool circuit or fixed value circuit

Menu → **Installer level** → **System configuration** → [HEATING1 ----] → **Target flow temp.: Day**

- You can use this function to set the target flow temperature for the pool circuit and/or the fixed value circuit within the time period (day).

7.7.6 Setting the set-back target flow temperature for the pool circuit or fixed value circuit

Menu → **Installer level** → **System configuration** → [HEATING1 ----] → **T.fl.temp.: Set-back**

- You can use this function to set the target flow temperature for the pool circuit or fixed value circuit outside of the time period (night).

7.7.7 Setting the target return temperature for the "increase in return flow" circuit type

Menu → **Installer level** → **System configuration** → [HEATING1 ----] → **Target return temp.**

- You can use this function to set the target return temperature for the "increase in return flow" circuit type.

7.7.8 Setting the minimum cooling target flow value

Menu → **Installer level** → **System configuration** → [HEATING1 ----] → **Min. cool. fl. tgt temp.**

- If a heat pump is connected and the **Cooling possible** function is activated for the heating circuit, you can set the minimum target flow value for the **Cooling possible** mode.

The system control regulates the heating circuit at the minimum cooling target flow value, even if the end user has set a lower desired temperature for cooling.

7.7.9 Reading the actual temperature

Menu → **Installer level** → **System configuration** → [HEATING1 ----] → **Current temperature**

- You can use this function to read the actual temperature of the heating circuit.

7.7.10 Setting the excess temperature

Menu → **Installer level** → **System configuration** → [HEATING1 ----] → **Excessive temp.**

- You can use this function to set the excess temperature. The excess temperature increases the current set target temperature of the heating circuit by the value that is set.

On mixer circuits with fixed mixing, this function means that the set target temperature can be reached in pre-heat mode, even though the temperature of the mixer circuit drops substantially.

The function also allows for an optimal control range for operating the mixer valve. Stable operation is only possible if the mixer valve only rarely has to move to the limit stop. This ensures improved quality of control.

7.7.11 Setting the temperature threshold for deactivating the heating circuit

Menu → Installer level → System configuration → [HEATING1 ----] → Max limit outs.temp.

- You can use this function to set the temperature threshold. If the outdoor temperature is greater than the switch-off threshold set, the system control deactivates heating mode.

7.7.12 Setting the minimum flow temperature for the heating circuit

Menu → Installer level → System configuration → [HEATING1 ----] → Minimum temperature

- You can use this function to specify a minimum value for the flow temperature in heating mode for each heating circuit; the control system will not fall below this value. The system control compares the calculated flow temperature with the value set for the minimum temperature and, if there is a difference, adjusts this to the higher value.

7.7.13 Setting the maximum flow temperature for the heating circuit

Menu → Installer level → System configuration → [HEATING1 ----] → Maximum temperature

- You can use this function to specify a maximum value for the flow temperature in heating mode for each heating circuit; the control system will not exceed this value. The system control compares the calculated flow temperature with the value set for the maximum temperature and, if there is a difference, adjusts to the lower value.

7.7.14 Specifying control behaviour outside time periods

Menu → Installer level → System configuration → [HEATING1 ----] → Auto Off mode

- This function enables you to specify, for each heating circuit separately, the system control functions in automatic mode outside active time periods. Default setting: **Eco**

You can select from two control behaviours, which you can adapt further by using room temperature modulation.

If you have set the **Thermost.** value in the **Room temp. mod.** function, the **Auto Off mode** function is ineffective. The system control always brings the target room temperature to 5 °C.

- **Eco:** The operating mode **Auto Off mode, Auto** (outside of the time period) and **off** are switched off. If a mixing circuit is connected, the heating pump is switched off and the heating circuit mixer is closed. The outdoor temperature is monitored. If the outdoor temperature falls below 4 °C, the system control switches the heating function on after the end of the frost protection delay time. The heating pump is activated. If a mixing circuit is connected, the heating pump and the heating circuit mixer are activated. The system control regulates the target room temperature at the set temperature **Set-back**. Despite the heating function being switched on, the heat generator is only active on demand. The heating function remains active

until the outdoor temperature rises above 4 °C, after which the system control switches the heating function off again, but the outdoor temperature monitoring remains active.

- **Set-back:** The heating function is switched on and the target room temperature is maintained at the set **Set-back** temperature.

7.7.15 Setting the heating curve

Menu → Installer level → System configuration → [HEATING1 ----] → Heating curve

- If the heating curve setting is not sufficient to control the living room climate according to the operator's wishes, you can adapt the heating curve setting made during installation.

If you activate the **Adaptive heat. curve** function, you must always adjust the value for the heating curve to the heating surface design.

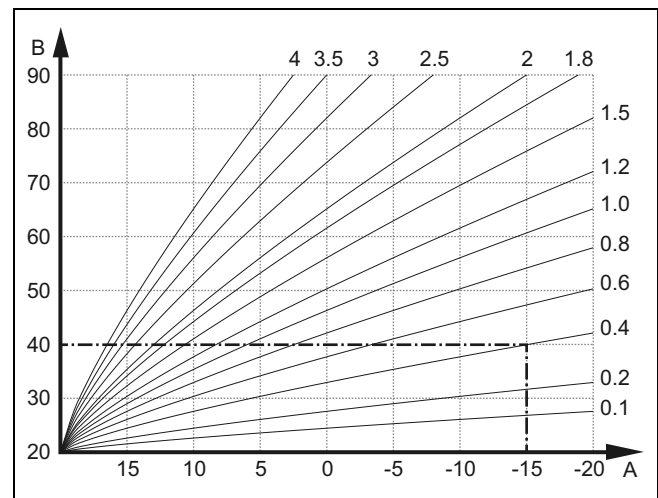

A Outside temperature °C B Target flow temperature °C

The illustration shows the possible heating curves of 0.1 to 4.0 for a target room temperature of 20 °C. If, for example, heating curve 0.4 is selected, a flow temperature of 40 °C is maintained at an outside temperature of -15 °C.

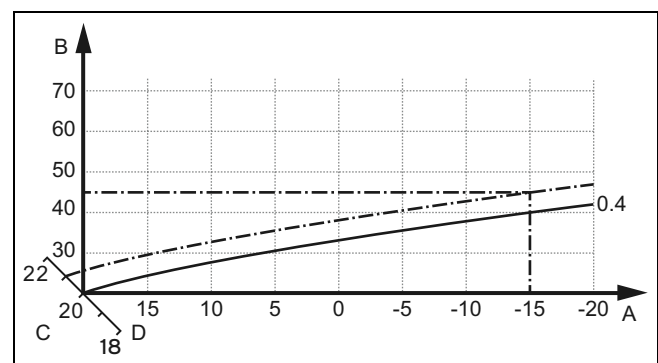

A Outdoor temperature °C C Target room temperature °C
B Target flow temperature °C D Axis a

If the heating curve 0.4 is selected and 21 °C is specified for the target room temperature, the heating curve is then translated, as shown in the figure. The heating curve is displaced according to the value of the room target temperature along axis a which is angled at 45°. At an outside temperature of -15 °C, the control system provides a flow temperature of 45 °C.

7.7.16 Activating Room temp. mod.

Menu → Installer level → System configuration → [HEATING1 ----] → Room temp. mod.

- This function allows you to define whether the temperature sensor integrated in the system control or in the remote control unit should also be used.

The prerequisite for this is:

- The system control is installed in the living room.
- Any remote control unit that is present is installed in the living room.
- In the **Zone assignment** function, the system control or the remote control unit is assigned to the zone in which the system control or remote control unit is installed. If you do not assign any zones, the **Room temp. mod.** function is ineffective.

None: The temperature sensor is not used for control.

Temp. mod.: The built-in temperature sensor measures the current room temperature in the reference room. This value is compared with the target room temperature and, if there is a difference, results in adjustment of the flow temperature by means of the so-called "Effective target room temperature". Effective room temp. target = set room temp. target + (set room temp. target - measured room temp. target). The effective target room temperature is then used for controlling instead of the set target room temperature.

Thermost.: This function works in the same way as the **Temp. mod.** function, however the zone is also switched off when the measured room temperature is + 3/16 K greater than the set target room temperature. When the room temperature falls + 2/16 K back below the target room temperature set, the zone is switched on again. The use of room temperature modulation, in combination with careful selection of the heating curve, leads to optimum control of the heating installation.

7.7.17 Activating Cooling possible

Menu → Installer level → System configuration → [HEATING1 ----] → Cooling possible

- When a heat pump is connected, you can activate the **Cooling** function for the heating circuit .

7.7.18 Activating the dew point monitoring

Menu → Installer level → System configuration → [HEATING1 ----] → Dew point monitoring

- You can use this function to activate the dew point monitoring.

If the dew point monitoring has been activated, the system control compares the set minimum cooling target flow value with the dew point+offset. The system control always selects the higher temperature so that no condensate can form.

7.7.19 Setting the end cooling temperature

Menu → Installer level → System configuration → [HEATING1 ----] → End OT cooling

- You can use this function to set the temperature threshold from which cooling switches off. If the outdoor temperature is lower than the temperature threshold set, the system control ends cooling mode.

7.7.20 Setting the dew point offset

Menu → Installer level → System configuration → [HEATING1 ----] → Offset dew point

- You can use this function to set the dew point offset.

The offset is a safety margin that is added to the dew point. The system control selects the maximum for the flow temperature calculated from the flow temperature that is set and the dew point + offset.

7.7.21 Reading the status of the external heat demand

Menu → Installer level → System configuration → [HEATING1 ----] → Status ext. heat dem.

- You can use this function to read the heat demand on an external input.

Depending on the configuration of the **VR 70** or **VR 71**, there is one external input for each heating circuit. You can connect an external zone controller, for example, to this external input.

7.7.22 Reading the heating pump status

Menu → Installer level → System configuration → [HEATING1 ----] → Pump status

- You can use this function to read the current status (**On, off**) of the heating pump for the heating circuit.

7.7.23 Reading the status of the heating circuit mixer

Menu → Installer level → System configuration → [HEATING2 ----] → Mixer status

- You can use this function to read the current status (**Opening, Closing, Stationary**) of the heating circuit mixer from **HEATING2**.

7.8 ZONE1

7.8.1 Deactivating the zone

Menu → Installer level → System configuration → [ZONE1 ----] → Zone activated

- You can use this function to deactivate the zone that you do not require.

All available zones appear on the display if the existing heating circuits are activated in the **Type of circuit** function.

Setting the type of circuit (→ Page 15)

7.8.2 Setting the day temperature

Menu → Installer level → System configuration → [ZONE1 ----] → Day temperature

- You can use this function to set the required temperature within the time period for the zone.

7.8.3 Setting the set-back temperature

Menu → Installer level → System configuration → [ZONE1 ----] → Set-back temp.

- You can use this function to set the required temperature outside of the time period for the zone.

The night temperature is the temperature to which the heating is to be reduced at times of low heat demand.

7.8.4 Reading the room temperature

Menu → Installer level → System configuration → [ZONE1 ----] → Room temperature

- You can use this function to read the current room temperature. To do this, the system control must be installed in the living room and assigned to a zone.

The system control has an integrated temperature sensor, which determines the room temperature.

7.8.5 Assigning a zone

Menu → Installer level → System configuration → [ZONE1 ----] → Zone assignment

- You can use this function to assign the unit (system control or remote control) that is installed in the zone to the selected zone. The control system also uses the room temperature sensor for the assigned unit.

If you have assigned a remote control unit, the remote control unit uses all of the values for the assigned zone.

If you do not assign any zones, the **Room temp. mod.** function is ineffective.

7.8.6 Reading the zone valve status

Menu → Installer level → System configuration → [ZONE1 ----] → Zone valve status

- You can use this function to read the current status of the zone valve (**Open, Closed**).

7.9 DHW circuit

7.9.1 Setting the cylinder

Menu → Installer level → System configuration [DHW circuit ----] → Cylinder

- You can use this function to activate or deactivate a cylinder for the hot water circuit.

If a cylinder is installed in the heating installation, the setting must always be active.

7.9.2 Reading the domestic hot water circuit's target flow temperature

Menu → Installer level → System configuration → [DHW circuit ----] → Target flow temp.

- You can use this function to read the target flow temperature of the domestic hot water circuit.

7.9.3 Setting the target cylinder temperature (domestic hot water)



Danger!

Risk of death from legionella.

Legionella multiply at temperatures below 60 °C.

- ▶ Ensure that the end user is familiar with all of the Anti-legionella measures in order to comply with the applicable regulations regarding legionella prevention.

Menu → Installer level → System configuration [DHW circuit ----] → Domestic hot water

Menu → Installer level → System configuration [HEATING1 ----] → Domestic hot water

- You can use this function to define the set target temperature (**Domestic hot water**) for a connected domestic hot water cylinder. Set the set target temperature on the system control in such a way that the heat demand of the end user is covered.

▶ Observe the applicable regulations regarding legionella prevention.

7.9.4 Reading the actual temperature of the domestic hot water cylinder

Menu → Installer level → System configuration [DHW circuit ----] → Current cyl. temp.

Menu → Installer level → System configuration [HEATING1 ----] → Current cyl. temp.

- You can use this function to read the measured cylinder temperature.

7.9.5 Reading the status of the cylinder charging pump

Menu → Installer level → System configuration [DHW circuit ----] → Cyl. charging pump

Menu → Installer level → System configuration [HEATING1 ----] → Cyl. charging pump

- You can use this function to read the status of the cylinder charging pump (**On, off**).

7.9.6 Reading the status of the circulation pump

Menu → Installer level → System configuration [DHW circuit ----] → Circulation pump

- You can use this function to read the status of the circulation pump (**On, off**).

7.9.7 Defining the day for the anti-legionella function

Menu → Installer level → System configuration [DHW circuit ----] → Anti-legionella day

- You can use this function to define whether the anti-legionella function is carried out daily or on a specific day.

If the anti-legionella function is activated, the water in the domestic hot water circuit is automatically heated to the target cylinder temperature of 70 °C (with 5 K hysteresis) at the scheduled times. The circulation pump is activated.

The function is terminated automatically when the cylinder temperature sensor measures a temperature of > 60 °C for more than 60 minutes, or after a period of 120 minutes has elapsed, to avoid getting "stuck" in this function if water is drawn simultaneously.

Factory setting = **off** means there is no Anti-legionella function.

If the **Days away from home scheduling** function is active, no anti-legionella function is carried out during these days.

The anti-legionella function is reactivated directly on the first day after the **Days away from home scheduling** function has expired and is carried out at the scheduled times.

If a heat pump is installed in the heating installation, the system control activates the back-up boiler for the anti-legionella function.

7.9.8 Defining the time for the anti-legionella function

Menu → Installer level → System configuration [DHW circuit ----] → Anti-legionella time

- You can use this function to define the time for executing the Anti-legionella function.

When the time is reached on the defined day, the function starts automatically.

If the **Days away from home scheduling** function is active at the same time, the anti-legionella function is not carried out.

7.9.9 Setting the hysteresis for cylinder charging

Menu → Installer level → System configuration [DHW circuit ----] → Cyl. boost hysteresis

- If a heat pump is connected, you can use this function to set a hysteresis for the cylinder charging.

For example: If the desired temperature is set to 55 °C and the temperature difference for cylinder charging is set to 10 K, cylinder charging begins as soon as the cylinder temperature drops to 45 °C.

7.9.10 Defining the offset for charging the domestic hot water cylinder

Menu → Installer level → System configuration [DHW circuit ----] → Cylinder boost offset

- If a heat pump is connected, you can use this function to specify an offset value (K) for the set hot water temperature. The domestic hot water cylinder is then charged to the flow temperature, which equates to the total of the set hot water temperature and this offset value.

7.9.11 Setting the maximum cylinder charging time

Menu → Installer level → System configuration [DHW circuit ----] → Max. cyl. charg. time

- If a heat pump is connected, you can use this function to set the maximum charge time for which the cylinder is charged without interruption.

The **off** setting means that there is no time limit for the cylinder charging time.

7.9.12 Setting the anti-cycling time for the hot water demand

Menu → Installer level → System configuration [DHW circuit ----] → DHW req. anti-cy time

- If a heat pump is connected, you can use this function to set a time period in which cylinder charging is blocked.

If the maximum cylinder charging time is reached but the domestic hot water cylinder connected has not yet reached its set target temperature, the **DHW req. anti-cy time** function takes effect.

7.9.13 Defining the overrun time for the cylinder charging pump

Menu → Installer level → System configuration [DHW circuit ----] → Ch. pump overrun time

- You can use this function to define an overrun time for the cylinder charging pump. The high flow temperature required for cylinder charging continues to be delivered to the cylinder as far as possible by means of the charge

pump overrun before the heating circuits (in particular, the burner circuit) are enabled again for the heating function.

When the set domestic hot water temperature (cylinder charging) is reached, the system control switches off the heat generator. The overrun time for the cylinder charging pump starts. The system control automatically deactivates the cylinder charging pump after the overrun time has elapsed.

7.9.14 Activating parallel cylinder charging (domestic hot water cylinder and mixing circuit)

Menu → Installer level → System configuration [DHW circuit ----] → Parallel cyl. charging

- You can use this function to define, for the connected mixing circuit, that the mixing circuit should continue to be heated during charging of the domestic hot water cylinder.

If the **Parallel cyl. charging** function is activated, the mixing circuits continue to be supplied while the cylinder is being charged. Provided there is a heat demand in the mixing circuit, the system control does not deactivate the heating pump in the mixing circuit. The non-mixed heating circuit is always switched off during cylinder charging.

7.10 Buffer cylinder

7.10.1 Reading the top cylinder temperature in the buffer cylinder

Menu → Installer level → System configuration [Buffer cylinder ----] → Cyl. temp.: top

- You can use this function to read the actual temperature in the upper section of the buffer cylinder.

7.10.2 Reading the bottom cylinder temperature in the buffer cylinder

Menu → Installer level → System configuration [Buffer cylinder ----] → Cyl. temp.: Bottom

- You can use this function to read the actual temperature in the lower section of the buffer cylinder.

7.10.3 Reading the top cylinder temperature for domestic hot water in the buffer cylinder

Menu → Installer level → System configuration [Buffer cylinder ----] → DHW temp. sensor, top

- You can use this function to read the actual temperature in the upper section of the buffer cylinder's hot water component.

7.10.4 Reading the bottom cylinder temperature for domestic hot water in the buffer cylinder

Menu → Installer level → System configuration [Buffer cylinder ----] → DHW tmp. sensor, bot.

- You can use this function to read the actual temperature in the lower section of the buffer cylinder's hot water component.

7.10.5 Reading the top cylinder temperature for heating in the buffer cylinder

Menu → Installer level → System configuration [Buffer cylinder ----] → Heat. temp. sens., top

- You can use this function to read the actual temperature in the upper section of the buffer cylinder's heating component.

7.10.6 Reading the bottom cylinder temperature for heating in the buffer cylinder

Menu → **Installer level** → **System configuration** [**Buffer cylinder ----**] → **Heat. temp. sens., bot.**

- You can use this function to read the current temperature in the lower section of the buffer cylinder's heating component.

7.10.7 Setting the max. target flow temperature in the buffer cylinder

Menu → **Installer level** → **System configuration** [**Buffer cylinder ----**] → **Max.DHW fl.targ.temp.**

- You can use this function to set the buffer cylinder's maximum target flow temperature for the domestic hot water station. The max. target flow temperature that is to be set must be lower than the max. flow temperature for the heat generator. While the cylinder's set target temperature is not reached, the system control does not allow the heat generator to go into heating mode.

You can find the maximum target flow temperature that the heat generator can achieve in the installation instructions for the heat generator.

If the max. target flow temperature that is set is too low, the domestic hot water station cannot provide the required target temperature for the cylinder.

7.11 Solar circuit

7.11.1 Reading the collector temperature

Menu → **Installer level** → **System configuration** → [**Solar circuit ----**] → **Collector temp.**

- You can use this function to read the current temperature on the collector temperature sensor.

7.11.2 Reading the status of the solar pump

Menu → **Installer level** → **System configuration** → [**Solar circuit ----**] → **Solar pump status**

- You can use this function to read the current status of the solar pump (**On, off**).

7.11.3 Reading the running time of the solar pump

Menu → **Installer level** → **System configuration** → [**Solar circuit ----**] → **Solar pump runtime**

- You can use this function to read the measured operating hours of the solar pump since start-up or since the last reset.

7.11.4 Resetting the solar pump running time

Menu → **Installer level** → **System configuration** → [**Solar circuit ----**] → **Reset runtime**

- You can use this function to reset the total operating hours of the solar pump to zero.

7.11.5 Reading the value of the solar yield sensor

Menu → **Installer level** → **System configuration** → [**Solar circuit ----**] → **Solar yield sensor**

- You can use this function to read the current value for the solar yield sensor.

7.11.6 Setting the flow rate of the solar circuit

Menu → **Installer level** → **System configuration** → [**Solar circuit ----**] → **Solar flow volume**

- In this function, enter the value for the volume flow. This value is used to calculate the solar yield.

If a **VMS 70** is installed in the heating installation, the **VMS 70** supplies the value for the volume flow. The system control ignores the value that is entered in this function.

7.11.7 Activating Solar pump boost

Menu → **Installer level** → **System configuration** → [**Solar circuit ----**] → **Solar pump boost**

- This function allows you to activate a pump kick for the solar pump, in order to speed up the temperature recording of the collector temperature.

Depending on the design, there is a time delay in some collectors during calculation of the measured value for temperature recording. You can use the **Solar pump boost** function to reduce the time delay. When this function is activated, the solar pump is switched on for 15 seconds (solar pump boost) if the temperature at the collector temperature sensor has risen by 2 K/hour. This transports the heated solar fluid to the point of measurement more quickly.

7.11.8 Setting the solar circuit protection

Menu → **Installer level** → **System configuration** → [**Solar circuit ----**] → **Solar circuit prot.**

- With this function, you can define a temperature threshold for the calculated collector temperature in the solar circuit.

If the available solar heat exceeds the current heat requirement (e.g. all cylinders fully charged), the temperature in the collector field may rise steeply. If the protection temperature set at the collector temperature sensor is exceeded, the solar pump is switched off to protect the solar circuit (pump, valves, etc.) against overheating. The solar pump is switched back on once the system has cooled down (35 K hysteresis).

7.11.9 Setting the minimum collector temperature

Menu → **Installer level** → **System configuration** → [**Solar circuit ----**] → **Min. collector temp**

- You can use this function to set the minimum collector temperature.

Defining the switch-on differential for solar charging (→ Page 21)

7.11.10 Setting the purging time for the solar circuit

Menu → **Installer level** → **System configuration** → [**Solar circuit ----**] → **Purging time**

- You can use this function to support the purging of the solar circuit.

The system control stops the function once the specified purging time has elapsed, the solar circuit protection function is active or the max. cylinder temperature has been exceeded.

7.11.11 Reading the current flow rate for the VMS 70

Menu → Installer level → System configuration → [Solar circuit ----] → Current flow rate

- You can use this function to read the measured flow rate (volume flow) for the **VMS 70**.

7.12 Solar cylinder 1

7.12.1 Defining the switch-on differential for solar charging

Menu → Installer level → System configuration → [Solar cylinder 1 ----] → Switch-on diff.

- This function allows you to define a differential value for starting solar charging. The temperature difference is measured between the lower cylinder temperature sensor and the collector temperature sensor.

If the temperature difference exceeds the differential value set and the minimum collector temperature set, the system control switches the solar pump on. The solar cylinder is charging. The differential value can be defined separately for two connected solar cylinders.

7.12.2 Defining the switch-off differential for solar charging

Menu → Installer level → System configuration → [Solar cylinder 1 ----] → Switch-off diff.

- This function allows you to define a differential value for stopping solar charging. The temperature difference is measured between the lower cylinder temperature sensor and the collector temperature sensor.

If the temperature difference falls below the differential value that is set, the system control switches the solar pump off. The solar cylinder is no longer charged. The switch-off differential temperature value must be at least 1 K less than the set switch-on differential temperature value.

7.12.3 Defining the maximum temperature for solar cylinder

Menu → Installer level → System configuration → [Solar cylinder 1 ----] → Maximum temperature

- This function allows you to define a maximum value as a limit for the solar cylinder temperature, in order to guarantee the highest possible yield from the solar cylinder heating, but also to ensure protection against calcification.

If the maximum temperature set on the bottom cylinder temperature sensor is exceeded, the system control switches the solar pump off. Solar charging is only enabled again once the temperature at the bottom cylinder temperature sensor has fallen by between 1.5 K and 9 K, depending on the maximum temperature. The maximum temperature set must not exceed the maximum permissible cylinder temperature of the cylinder that is used.

7.12.4 Reading the value for the bottom cylinder temperature sensor

Menu → Installer level → System configuration → [Solar cylinder 1 ----] → Cyl. temp.: Bottom

- You can use this function to read the current measured value for the bottom cylinder temperature sensor.

7.13 2nd differential temperature control

7.13.1 Defining the switch-on differential for the second differential temperature control

Menu → Installer level → System configuration → [2nd temperature difference control ----] → Switch-on diff.

- You can use this function to define a differential value for starting the differential temperature control, such as solar supported heating.

If the difference between differential temperature sensor 1 and differential temperature sensor 2 exceeds the specified switch-on differential and the minimum temperature at differential temperature sensor 1, the system control then controls the differential temperature output. The differential temperature control starts.

7.13.2 Defining the switch-off differential for the second differential temperature control

Menu → Installer level → System configuration → [2nd temperature difference control ----] → Switch-off diff.

- You can use this function to define a differential value for stopping the differential temperature control, such as solar supported heating.

If the difference between differential temperature sensor 1 and differential temperature sensor 2 falls below the specified switch-off differential or exceeds the maximum temperature at differential temperature sensor 2, the system control then controls the differential temperature output. The differential temperature control stops.

7.13.3 Setting the minimum temperature

Menu → Installer level → System configuration → [2nd temperature difference control ----] → Minimum temperature

- You can use this function to set the minimum temperature in order to start the differential temperature control.

Defining the switch-on differential for the second differential temperature control (→ Page 21)

7.13.4 Setting the maximum temperature

Menu → Installer level → System configuration → [2nd temperature difference control ----] → Maximum temperature

- You can use this function to set the maximum temperature in order to stop the differential temperature control.

Defining the switch-off differential for the second differential temperature control (→ Page 21)

7.13.5 Reading the value for differential temperature sensor 1

Menu → Installer level → System configuration → [2nd temperature difference control ----] → TD1 sensor

- You can use this function to read the current measured value for differential temperature sensor 1 (TD1).

7.13.6 Reading the value for differential temperature sensor 2

Menu → Installer level → System configuration → [2nd temperature difference control ----] → TD2 sensor

- You can use this function to read the current measured value for differential temperature sensor 2 (TD2).

7.13.7 Reading the status of the differential temperature control

Menu → **Installer level** → **System configuration** → [2nd temperature difference control ----] → **TD output**

- You can use this function to read the status of the differential temperature control.

7.14 Ventilation

7.14.1 Reading the air quality sensor

Menu → **Installer level** → **System configuration** → [Ventilation ----] → **Air quality sensor 1/2**

- You can use this function to read the measured values from the air quality sensor.

7.14.2 Setting the maximum value for air quality sensor

Menu → **Installer level** → **System configuration** → [Ventilation ----] → **Max. air qual. sensor**

- You can use this function to set a maximum value for the air quality.

If the air quality exceeds the maximum value specified, the system control activates the **recoVAIR.../4** ventilation unit accordingly. You will find a detailed functional description in the **recoVAIR.../4** manual.

7.15 Radio link

7.15.1 Reading the reception strength for the system control

Menu → **Installer level** → **System configuration** → [RF connection ----] → **Control reception**

- You can use this function to read how strong the reception strength between the radio receiver unit and the system control is.

4: The radio link is within the acceptable range. If the reception strength is < 4, the radio link is not stable.

10: The radio link is highly stable.

7.15.2 Reading the reception strength for the outdoor temperature sensor

Menu → **Installer level** → **System configuration** → [RF connection ----] → **OT sensor reception**

- You can use this function to read how strong the reception strength between the radio receiver unit and the outdoor temperature sensor is.

4: The radio link is within the acceptable range. If the reception strength is < 4, the radio link is not stable.

10: The radio link is highly stable.

7.16 Selecting the wiring centre for sensor/actuator test

Menu → **Installer level** → **Sensor/actuator test** → [Select Unit]

- This function allows you to select a connected wiring centre for the sensor and actuator test. The system control lists the actuators and sensors for the selected wiring centre. If you confirm the selection of an actuator using **OK**, the system control activates the relay. The actuator's function can now be checked. Only the activated actuator is active, all other actuators are "deactivated" at this time.

For example, you can move a mixing valve in the "Open" direction and check that it is connected the right way round or activate a pump and check that it starts up. If you select a sensor, the system control shows the measured value of the selected sensor. For the selected component, read the measured values from the sensors and check whether the individual sensors are providing the expected values (temperature, pressure, flow rate, etc.).

7.17 Activating the screed-drying function



Note

All heat pumps except for the hybrid heat pump are used for screed drying.

Menu → **Installer level** → **Screed-drying function** → **HEATING1**

- You can use this function to "dry heat" freshly laid screed in accordance with the construction regulations, according to a defined time and temperature schedule.

When screed drying is activated, all the selected operating modes are interrupted. The system control controls the flow temperature of the controlled heating circuit according to a pre-set program, regardless of the outdoor temperature.

Days after starting the function	Target flow temperature for this day [°C]
1	25
2	30
3	35
4	40
5	45
6-12	45
13	40
14	35
15	30
16	25
17-23	10 (frost protection function, pump in operation)
24	30
25	35
26	40
27	45
28	35
29	25

The display shows the current day and the target flow temperature. You can manually set the current day.

The day is always changed at 00:00, irrespective of when the function starts.

After a mains Off/On, screed drying starts with the last active day.

The function ends automatically when the last day of the temperature profile has elapsed (day = 29) or if you set the start day to 0 (day = 0).

7.18 Changing the code for Installer level

Menu → Installer level → Change code

- You can use this function to change the access code for the **Installer level**.

If the code is no longer available, you must reset the system control to the factory setting in order to obtain access to Installer level again.

Resetting to factory setting (→ Page 10)

8 Handing over to the end user

8.1 Handing the product over to the end user

- ▶ Inform the operator of how to handle and operate their product.
- ▶ Provide the operator with all relevant instructions and unit documentation for safe-keeping.
- ▶ Tell the operator the article number of the product.
- ▶ Go through the operating instructions with the operator.
- ▶ Answer any questions the end user may have.
- ▶ In particular, draw the end user's attention to the safety information that they must follow.



Danger!

Risk of death from legionella.

Legionella multiply at temperatures below 60 °C.

- ▶ Ensure that the end user is familiar with all of the Anti-legionella measures in order to comply with the applicable regulations regarding legionella prevention.
-
- ▶ Point out the anti-legionella function to the end user.
 - ▶ Inform the end user that they must have the product maintained in accordance with the specified intervals.
 - ▶ Advise the end user that the system control may not work as well as it should do if it is removed from its intended installation site.
 - ▶ Inform the end user that the reception strength between the radio receiver unit and the system control or outdoor temperature sensor is not affected by electrical devices or building components.

9 Troubleshooting

9.1 Troubleshooting measures

If a fault occurs in the heating installation,  will appear in the display together with a fault message.

You can also read all current error messages under the following menu item:

Menu → Installer level → System configuration → [System ----] → **Fault status**

- If a fault is present, the status **Fault list** is displayed. In this case, the right-hand selection button is for the **Display** function. You can press the right-hand selection button to display the list of fault messages.



Note

Not all fault messages in the list will appear automatically on the basic display.

Troubleshooting faults (→ Appendix D.1)

Troubleshooting errors (→ Appendix D.2)

9.2 Maintenance message

If maintenance is required, the system control displays a maintenance message in the display.

- ▶ Carry out the maintenance instructions in accordance with the operating or installation instructions for the unit shown.
- ▶ In the **Service date** function, set when the next maintenance is due (→ Page 11).

Overview of the maintenance messages

Maintenance messages (→ Appendix E)

10 Spare parts

10.1 Procuring spare parts

The original components of the product were also certified by the manufacturer as part of the declaration of conformity. If you use other, non-certified or unauthorised parts during maintenance or repair work, this may result in the product no longer meeting the applicable standards, thereby voiding the conformity of the product.

We strongly recommend that you use original spare parts from the manufacturer as this guarantees fault-free and safe operation of the product. To receive information about the available original spare parts, contact the contact address provided on the back page of these instructions.

- ▶ If you require spare parts for maintenance or repair work, use only the spare parts that are permitted for the product.

10.2 Changing the batteries



Danger! **Risk of death caused by unsuitable batteries!**

If batteries – whether rechargeable or non-rechargeable – are replaced with the wrong type of battery, there is a risk of explosion.

- ▶ Ensure that you use the correct battery type when replacing batteries.
- ▶ Dispose of used batteries in accordance with the instructions in this manual.

- ▶ Replace the batteries as described in the product's operating instructions.

10.3 Replacing the outdoor temperature sensor

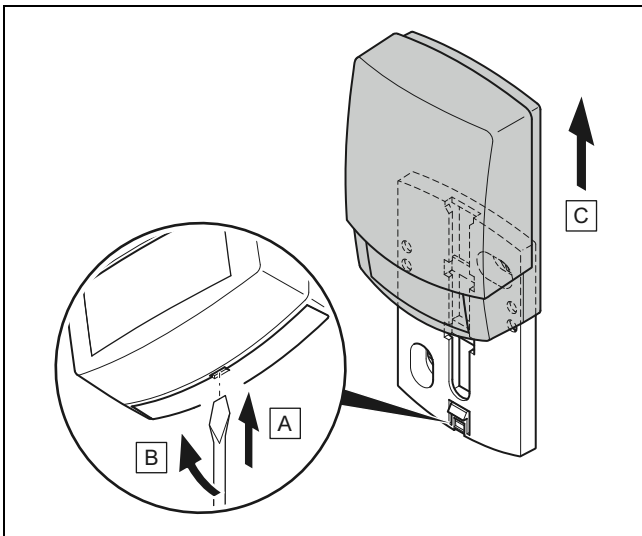

1. Remove the outdoor temperature sensor from the wall base as shown in the figure.
2. Unscrew the wall-mounting base from the wall.
3. Dispose of the outdoor temperature sensor. (→ Page 24)
4. Mount the wall base. (→ Page 7)
5. Press the pair button on the radio receiver unit.
◀ The pairing process starts. The LED flashes green.
6. Start up the outdoor temperature sensor and fit it to the wall base. (→ Page 7)

10.4 Disposing of the outdoor temperature sensor if defective



Note

The outdoor temperature sensor has a reserve power supply lasting approximately 30 days. During this time the outdoor temperature sensor will continue to send radio signals even if defective. If the outdoor temperature sensor is defective and within range of the radio receiver unit, the radio receiver unit will receive signals from the defective yet intact outdoor temperature sensor.

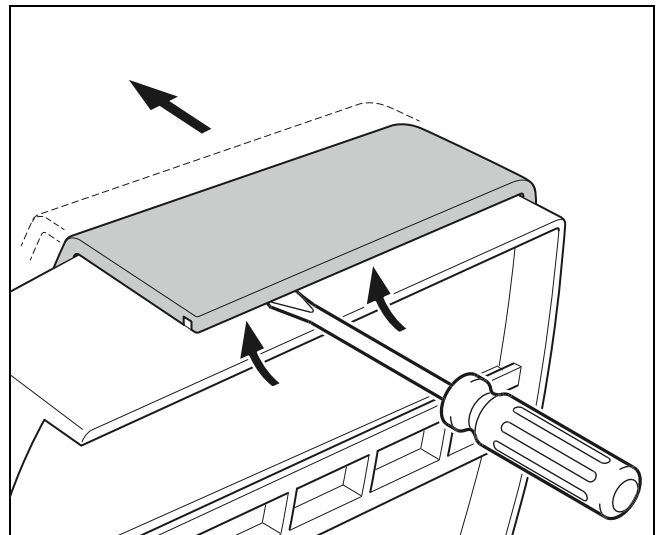

1. Open the outdoor temperature sensor as shown in the figure.

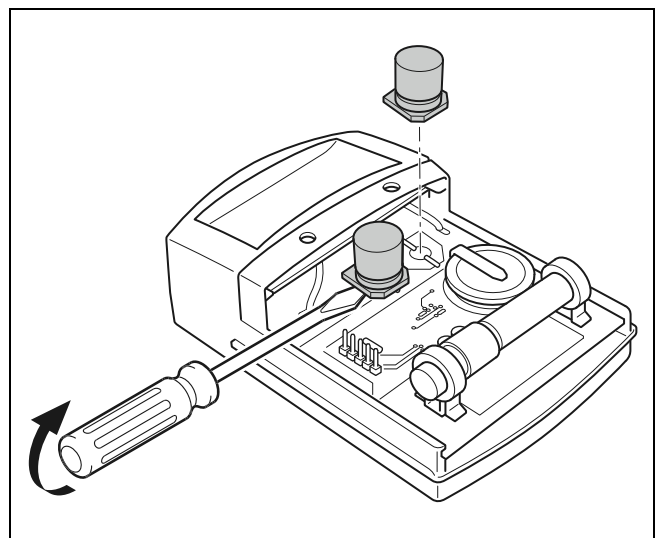

2. Remove the capacitors as shown in the figure.

11 Decommissioning

11.1 Decommissioning the heating installation

- ▶ Decommission all system components of the heating installation, as described in the installation instructions for the individual system components.

11.1.1 Removing the system control from the wall

1. Take the system control out of the unit mounting bracket.
2. Remove the batteries.
3. Remove the cover on the unit mounting bracket.
4. Unscrew the unit mounting bracket from the wall.

11.1.2 Removing the outdoor temperature sensor from the wall

1. Take the outdoor temperature sensor out of the wall base.
2. Unscrew the wall base from the wall.
3. Dispose of the outdoor temperature sensor.
(→ Page 24)

11.1.3 Removing the radio receiver unit from the heat generator

1. Open the radio receiver unit.
2. Disconnect the eBUS lines from the radio receiver unit's terminal block.
3. Disconnect the eBUS lines from the heat generator's terminal block.
4. Unscrew the wall base from the wall.

12 Recycling and disposal

Packaging

- ▶ Dispose of the packaging correctly.

This product is an electrical or electronic unit within the context of EU Directive 2012/19/EU. The unit was developed and manufactured using high-quality materials and components. These can be recycled and reused.

Find out about the regulations that apply in your country regarding the separate collection of waste electrical or electronic equipment. Correctly disposing of old units protects the environment and people against potential negative effects.

- ▶ Dispose of the packaging correctly.
- ▶ Observe all relevant regulations.

Disposing of the product



■ If the product is labelled with this symbol:

- ▶ In this case, do not dispose of the product with the household waste.
- ▶ Instead, hand in the product to a collection centre for waste electrical or electronic equipment.

Disposing of batteries



■ If the product contains batteries that are labelled with this symbol:

- ▶ In this case, dispose of the batteries at a collection point for batteries.
 - ◁ **Prerequisite:** The batteries can be removed from the product without causing any destruction. Otherwise, the batteries are disposed of together with the product.
- ▶ In accordance with the legal regulations, the end user is obligated to return used batteries.

Deleting personal data

Personal data may be misused by unauthorised third parties.

If the product contains personal data:

- ▶ Ensure that there is no personal data on or in the product (e.g. online login details or similar) before you dispose of the product.

13 Customer service

For contact details for our customer service department, you can write to the address that is provided on the back page, or you can visit www.vaillant.co.uk.

14 Technical data

14.1 System control

Battery type	LR06
Rated surge voltage	330 V
Frequency band	868.0 to 868.6 MHz
Max. transmission power	< 25 mW
Range outdoors	≤ 100 m
Range indoors	≤ 25 m
Pollution degree	2
IP rating	IP 20
Protection class	III
Temperature for the ball pressure test	75 °C
Maximum permitted environmental temperature	0 to 60 °C
Current room air humidity	20 to 95 %
Mode of operation	Type 1
Height	115 mm
Width	147 mm
Depth	50 mm

14.2 Radio receiver unit

Rated voltage	9 to 24 V ~
Rated current	< 50 mA
Rated surge voltage	330 V
Frequency band	868.0 to 868.6 MHz
Max. transmission power	< 25 mW
Range outdoors	≤ 100 m
Range indoors	≤ 25 m
Pollution degree	2
IP rating	IP 20
Protection class	III
Temperature for the ball pressure test	75 °C
Maximum permitted environmental temperature	0 to 60 °C
Rel. room humidity	35 to 90 %
Supply line cross-section	0.75 to 1.5 mm ²
Height	115 mm
Width	147 mm
Depth	50 mm

14.3 Outdoor temperature sensor

Power supply	Solar cell with energy store
Reserve power supply (with full energy store)	≈30 days
Rated surge voltage	330 V
Frequency band	868.0 to 868.6 MHz
Max. transmission power	< 25 mW
Range outdoors	≤ 100 m
Range indoors	≤ 25 m
Pollution degree	2
Level of protection	IP 44
Protection class	III
Temperature for the ball pressure test	75 °C
Permissible operating temperature	-40 to 60 °C
Height	110 mm
Width	76 mm
Depth	41 mm

Appendix

A Setting values for basic system diagram, VR 70 and VR 71

A.1 Basic system diagram configuration

Each heating installation is based on a system diagram with corresponding connection diagram. A separate basic diagram book contains the basic system diagrams and the corresponding wiring diagrams with explanations.

A.2 Gas-/oil-fired condensing boiler (eBUS)

Cylinder	Equipment	Heating circuits	Set value for		
			Basic system diagram	VR 70	VR 71
Monovalent domestic hot water cylinder or combi cylinder	Cylinder charging using the condensing boiler	1 direct	1		
Monovalent domestic hot water cylinder or combi cylinder	Cylinder charging using the condensing boiler Low loss header for heating circuits only	1 direct 1 mixed	1	1	
Monovalent domestic hot water cylinder or combi cylinder	Cylinder charging using the condensing boiler Low loss header for heating circuits only	2 mixed	1	5	
Monovalent domestic hot water cylinder or combi cylinder	Cylinder charging using the condensing boiler Low loss header for heating circuits only	3 mixed	1		3
Monovalent domestic hot water cylinder or combi cylinder	Low loss header for heating circuits and domestic hot water cylinders	1 direct 1 mixed	2	1	
Monovalent domestic hot water cylinder or combi cylinder	Low loss header for heating circuits and domestic hot water cylinders	3 mixed	2		3

A.3 Gas-/oil-fired condensing unit (eBUS) and solar hot water support

Cylinder	Equipment	Heating circuits	Setting for		
			System diagram	VR 70	VR 71
Bivalent domestic hot water cylinder	Cylinder charging using a condensing unit and solar heat	1 direct	1	6	
Bivalent domestic hot water cylinder	Cylinder charging using a condensing unit and solar heat	3 mixed	1		2

A.4 Gas-/oil-fired condensing unit (eBUS) and solar hot water and heating support

Cylinder	Equipment	Heating circuits	Setting for		
			System diagram	VR 70	VR 71
Combi storage tank	Hydraulic block Low loss header for heating circuits only	1 mixed	2	12	
Combi storage tank	Hydraulic block Low loss header for heating circuits only	3 mixed	2		2
alISTOR buffer cylinder	Buffer cylinder charging using a condensing unit and solar heat	1 mixed	1	3	
alISTOR buffer cylinder	Buffer cylinder charging using a condensing unit and solar heat	3 mixed	1		6

A.5 aroTHERM or flexoTHERM

Cylinder	Equipment	Heating circuits	Setting for		
			System diagram	VR 70	VR 71
Monovalent domestic hot water cylinder for heat pump		1 direct	8		
Monovalent domestic hot water cylinder for heat pump		1 direct 1 mixed	8	1	
Monovalent domestic hot water cylinder for heat pump		1 mixed 1 PV	8	1	
Monovalent domestic hot water cylinder for heat pump		2 mixed	8	5	
Monovalent domestic hot water cylinder for heat pump	Buffer cylinder for heating circuits only	3 mixed	8		3

A.6 aroTHERM and domestic hot water cylinder downstream of low loss header

Cylinder	Equipment	Heating circuits	Setting for		
			System diagram	VR 70	VR 71
Monovalent domestic hot water cylinder for heat pump	Low loss header for heating circuits and cylinders	1 direct 1 mixed	16	1	
Monovalent domestic hot water cylinder for heat pump	Low loss header for heating circuits and cylinders	3 mixed	16		3

A.7 aroTHERM or flexoTHERM and solar hot water support

Cylinder	Equipment	Heating circuits	Setting for		
			System diagram	VR 70	VR 71
Bivalent domestic hot water cylinder for heat pump	Cylinder charging using a heat pump and solar heat	1 direct	8	6	
Bivalent domestic hot water cylinder for heat pump	Cylinder charging using a heat pump and solar heat	3 mixed	8		2

A.8 aroTHERM or flexoTHERM and solar hot water and heating support

Cylinder	Equipment	Heating circuits	Setting for		
			System diagram	VR 70	VR 71
aiIStOR buffer cylinder	Buffer cylinder charging using a heat pump and solar heat	1 mixed	8	3	
aiIStOR buffer cylinder	Buffer cylinder charging using a heat pump and solar heat	3 mixed	8		6

A.9 aroTHERM with system separation

Cylinder	Equipment	Heating circuits	Setting for		
			System diagram	VR 70	VR 71
Monovalent domestic hot water cylinder for heat pump	Heat exchanger module for heat pump	1 direct	10		
Monovalent domestic hot water cylinder for heat pump	Heat exchanger module for heat pump	1 direct 1 mixed	10	1	
Monovalent domestic hot water cylinder for heat pump	Heat exchanger module for heat pump	2 mixed	10	5	
Monovalent domestic hot water cylinder for heat pump	Heat exchanger module for heat pump	3 mixed	10		3

A.10 aroTHERM with auxiliary heater and system separation

Cylinder	Equipment	Heating circuits	Setting for		
			System diagram	VR 70	VR 71
Monovalent domestic hot water cylinder for heat pump	Heat exchanger module for heat pump	1 direct	11		
Monovalent domestic hot water cylinder for heat pump	Heat exchanger module for heat pump	1 direct 1 mixed	11	1	
Monovalent domestic hot water cylinder for heat pump	Heat exchanger module for heat pump	2 mixed	11	5	
Monovalent domestic hot water cylinder for heat pump	Heat exchanger module for heat pump	3 mixed	11		3

A.11 aroTHERM with system separation and solar hot water support

Cylinder	Equipment	Heating circuits	Setting for		
			System diagram	VR 70	VR 71
Bivalent domestic hot water cylinder for heat pump	Cylinder charging using a heat pump and solar heat Heat exchanger module for heat pump	1 direct	11	6	
Bivalent domestic hot water cylinder for heat pump	Cylinder charging using a heat pump and solar heat Heat exchanger module for heat pump	3 mixed	11		2

A.12 geoTHERM 3 kW, hot water generation using a gas-fired condensing boiler (eBUS)

Cylinder	Equipment	Heating circuits	Setting for		
			System diagram	VR 70	VR 71
Monovalent domestic hot water cylinder or combi cylinder	Cylinder charging using the condensing unit	1 direct	6		
Monovalent domestic hot water cylinder or combi cylinder	Cylinder charging using the condensing unit Hydraulic module	1 direct 1 mixed	6	1	
Monovalent domestic hot water cylinder or combi cylinder	Cylinder charging using the condensing unit 2-zone kit	1 direct 1 mixed	7	1	

A.13 aroTHERM or flexoTHERM, hot water generation using a gas-fired condensing boiler (eBUS)

Cylinder	Equipment	Heating circuits	Setting for		
			System diagram	VR 70	VR 71
Monovalent domestic hot water cylinder or combi cylinder	Cylinder charging using the condensing unit Hydraulic module	1 direct 1 mixed	9	1	
Monovalent domestic hot water cylinder or combi cylinder	Cylinder charging using the condensing unit Hydraulic module	2 mixed	9	5	
Monovalent domestic hot water cylinder or combi cylinder	Cylinder charging using the condensing unit Hydraulic module	3 mixed	9		3

A.14 aroTHERM with system separation, hot water generation using a gas-fired condensing boiler (eBUS)

Cylinder	Equipment	Heating circuits	Setting for		
			System diagram	VR 70	VR 71
Monovalent domestic hot water cylinder for heat pump	Cylinder charging using the condensing unit Heat exchanger module for heat pump	1 direct	10		
Monovalent domestic hot water cylinder for heat pump	Cylinder charging using the condensing unit Heat exchanger module for heat pump	1 direct 1 mixed	10	1	
Monovalent domestic hot water cylinder for heat pump	Cylinder charging using the condensing unit Heat exchanger module for heat pump	2 mixed	10	5	
Monovalent domestic hot water cylinder for heat pump	Cylinder charging using the condensing unit Heat exchanger module for heat pump	2 mixed	10		3

A.15 aroTHERM or flexoTHERM, hot water generation using a heat pump and gas-fired condensing boiler (eBUS)

Cylinder	Equipment	Heating circuits	Setting for		
			System diagram	VR 70	VR 71
Monovalent domestic hot water cylinder for heat pump	Cylinder charging using a condensing unit and heat pump Hydraulic module	1 direct 1 mixed	12	1	
Monovalent domestic hot water cylinder for heat pump Buffer cylinder	Cylinder charging using a condensing unit and heat pump Buffer cylinder for heating circuits only	2 mixed	12	5	
Monovalent domestic hot water cylinder for heat pump Buffer cylinder	Cylinder charging using a condensing unit and heat pump Buffer cylinder for heating circuits only	3 mixed	12		3

A.16 aroTHERM with system separation, hot water generation using a heat pump and gas-fired condensing boiler (eBUS)

Cylinder	Equipment	Heating circuits	Setting for		
			System diagram	VR 70	VR 71
Monovalent domestic hot water cylinder for heat pump	Cylinder charging using a condensing unit and heat pump Hydraulic module Heat exchanger module	1 direct 1 mixed	13	1	
aIISTOR buffer cylinder	Buffer cylinder charging using a condensing unit and heat pump Hydraulic module Heat exchanger module	2 mixed	13	5	
Monovalent domestic hot water cylinder for heat pump	Cylinder charging using a condensing unit and heat pump Hydraulic module Heat exchanger module	3 mixed	13		3

A.17 aroTHERM and gas-fired condensing boiler (eBUS), heat pump cascade option

Cylinder	Equipment	Heating circuits	Setting for		
			System diagram	VR 70	VR 71
Buffer cylinder	Domestic hot water cylinder downstream of low loss header/buffer cylinder Buffer cylinder charging using the system controller	1 direct 1 mixed	16	1	
aIISTOR buffer cylinder	Domestic hot water cylinder downstream of low loss header/buffer cylinder Buffer cylinder charging using the system controller	1 direct 1 mixed	16	3	
Buffer cylinder	Domestic hot water cylinder downstream of low loss header/buffer cylinder Buffer cylinder charging using the system controller	3 mixed	16		3
aIISTOR buffer cylinder		3 mixed	16		6

B Overview of the setting options

B.1 Installer level

Setting level	Values		Unit	Increment, select	Default setting
	Min.	Max.			
Installer level →					
Enter code	000	999		1	000
Installer level → Service information → Enter contact details →					
Phone number	1	12	Numbers	0 to 9, blank spaces, hyphen	
Installer	1	12	Figures	A to Z, 0 to 9, space	
Installer level → Service information → Service date →					
Next service on			Date		
Installer level → System configuration →					
System ----					
Fault status	Current value*				
Water pressure	Current value		bar		
System status	Current value			Standby, Heat. mode, Cooling, DHW	
Frost protect. delay	0	12	h	1	4
OT constant heating	off, -25	10	°C	1	off
Control modules	Display			Software version	
Adaptive heat. curve	Current value			Yes, No	No
Configure heat. circ.				All, Zone	Zone
Automatic cooling				Yes, No	No
Start OT cooling	10	30	°C	1	21
Source regeneration				Yes, No	No
Current room air hum.	Current value		%		
Current dew point	Current value		°C		
Hybrid manager				triVAI, Biv. point	Biv. point
Heat. bivalence point	-30	20	°C	1	0
DHW bivalence point	-20	20	°C	1	-7
Alternative point	off, -20	40	°C	1	off
* If no fault is present, the status is No fault . If there is a fault, Fault list appears and you can read the fault message in the "Fault messages" section.					

Setting level	Values		Unit	Increment, select	Default setting
	Min.	Max.			
T. emergency mode	20	80	°C	1	25
Auxiliary heater type				condens., non cond., Electric	condens.
Energy supplier				HP off, BH off, HP&BH off, Heat. off, Cooling off, Ht./cl. off	HP off
Auxiliary heater for				Inactive, Heating, DHW, DHW+heat.	DHW+heat.
System flow temp.	Current value		°C		
Buff. cyl. offs.	0	15	K	1	10
Actuation reversal				Off, On	Off
Actuation sequence	Current sequence of the heat generators without auxiliary heating				
System diagram configuration ----					
System diagram	1	16		1, 2, 6, 7, 8, 9, 10, 11, 12, 13, 16	1
Config.: VR71	1	11		1	3
Config.: VR70 addr. 1	1	12		1	1
MA VR70, addr. 1				No funct., Charg.pump, Circ. pump, Cool.signal, Leg. pump, HC pump	No funct.
MA VR71				No funct., Charg.pump, Circ. pump, Cool.signal, Leg. pump, TD con.	No funct.
Additional module ----					
Multi-funct. output 2				HK-2P, Circ. pump, Dehumid., Zone, Leg. pump	Circ. pump
Aux. heater output				off, Stage 1, Stage 2, Stage 3	Stage 3
Multi-funct. Input				Not conn., Circ. boost, PV	Circ. boost
Heat pump 1 ----					
Heat generator 1 ----					
Additional module ----					
Status	Current value			Standby, Heat. mode, Cooling, DHW	
Current flow temp.	Current value		°C		
HEATING1 ----					
Type of circuit				Inactive, Heating, Fixed val., DHW, Ret.fl.incr.Pool,	Heating
Status	Current value			off, Heat. mode, Cooling, DHW	
Target flow temp.	Current value		°C		
Target flow temp. pool	Current value		°C		
Target flow temp.: Day	5	90	°C	1	65
T.fl.temp.: Set-back	5	90	°C	1	65
Target return temp.	15	80	°C	1	30
Min. cool. fl. tgt temp.	7	24	°C	1	20
Current temperature	Current value		°C		
Excessive temp.	0	30	K	1	0
Max limit outs.temp.	10	99	°C	1	21
Minimum temperature	15	90	°C	1	15
Maximum temperature	15	90	°C	1	90
Auto Off mode				Eco, Set-back	Eco
Heating curve	0.1	4.0		0.05	1.2
Room temp. mod.				None, Temp. mod., Thermost.	None
* If no fault is present, the status is No fault . If there is a fault, Fault list appears and you can read the fault message in the "Fault messages" section.					

Setting level	Values		Unit	Increment, select	Default setting
	Min.	Max.			
Cooling possible	Current value			Yes, No	No
Dew point monitoring	Current value			Yes, No	Yes
End OT cooling	4	25	°C	1	4
Offset dew point	-10	10	K	0.5	2
Status ext. heat dem.	Current value			off, On	
Pump status	Current value			off, On	
Mixer status	Current value			Opening, Stationary, Closing	
ZONE1 ----					
Zone activated	Current zone			Yes, No	
Day temperature	5	30	°C	0.5	20
Set-back temp.	5	30	°C	0.5	15
Room temperature	Current value		°C		
Zone assignment				Without, VRC700, VR91 ad.1, to VR91 ad.3	Without
Zone valve status	Current value			Closed, Open	
DHW circuit ----					
Cylinder				active, Inactive	active
Target flow temp.	Current value		°C		
Current cyl. temp.	Current value		°C		
Cyl. charging pump	Current value			off, On	
Circulation pump	Current value			off, On	
Anti-legionella day				off, Monday, Tuesday, Wednesday, Thursday, Friday, Saturday, Sunday, Mon-Sun	off
Anti-legionella time	00:00	24:00	hr:min	00:10	04:00
Cyl. boost hysteresis	3	20	K	0.5	5
Cylinder boost offset	0	40	K	1	25
Max. cyl. charg. time	off, 20	120	min	5	45
DHW req. anti-cy time	0	120	min	5	30
Ch. pump overrun time	0	10	min	1	5
Parallel cyl. charging				off, On	off
Buffer cylinder ----					
Cyl. temp.: top	Current value		°C		
Cyl. temp.: Bottom	Current value		°C		
DHW temp. sensor, top	Current value		°C		
DHW tmp. sensor, bot.	Current value		°C		
Heat. temp. sens., top	Current value		°C		
Heat. temp. sens., bot.	Current value		°C		
Max.DHW fl.targ.temp.	60	80	°C	1	80
Solar circuit ----					
Collector temp.	Current value		°C		
Solar pump status	Current value			off, On	
Solar pump runtime	Current value		h		
Reset runtime				No, Yes	No
Solar yield sensor	Current value		°C		
Solar flow volume	0.0	165.0	l/min	0.1	
Solar pump boost				off, On	off
Solar circuit prot.	110	150	°C	1	130
Min. collector temp	0	99	°C	1	20
* If no fault is present, the status is No fault . If there is a fault, Fault list appears and you can read the fault message in the "Fault messages" section.					

Setting level	Values		Unit	Increment, select	Default setting
	Min.	Max.			
Purging time	0	600	min	10	
Current flow rate	0.0	165.0	l/min	0.1	
Solar cylinder 1 ----					
Switch-on diff.	2	25	K	1	12
Switch-off diff.	1	20	K	1	5
Maximum temperature	0	99	°C	1	75
Cyl. temp.: Bottom	Current value		°C		
2nd temperature difference control ----					
Switch-on diff.	1	20	K	1	5
Switch-off diff.	1	20	K	1	5
Minimum temperature	0	99	°C	1	0
Maximum temperature	0	99	°C	1	99
TD1 sensor	Current value		°C		
TD2 sensor	Current value		°C		
TD output				off, On	off
Ventilation ----					
Air quality sensor 1	Current value		ppm		
Air quality sensor 2	Current value		ppm		
Air quality sensor 3	Current value		ppm		
Max. air qual. sensor	400	3000	ppm	100	1000
RF connection ----					
Control reception	0	10		1	
OT sensor reception	0	10		1	
Installer level → Sensor/actuator test →					
Unit				No module, VR70 ad.1, VR71	
Actuator				No actuat., R1, to R12	
Sensor				No sensor, S1, to S13	
Installer level → HEATING1 → Screed-drying function →					
Day	00	29	Day	1	00
Temperature	Current value		°C	1	
Installer level → Change code →					
New code	000	999		1	00
* If no fault is present, the status is No fault . If there is a fault, Fault list appears and you can read the fault message in the "Fault messages" section.					

B.2 Functions for the heating circuit

Depending on what the heating circuit is used for (heating circuit/direct circuit, pool circuit, fixed value circuit, etc.), specific functions are available in the system control. You can use the table to read which functions appear on the system control's display for the selected type of circuit.

Available function	Setting for the Type of circuit function					
	Heating		Pool circuit	Fixed value circuit	Increase in return flow	DHW circuit
	Direct circuit	Mixing circuit				
Reading the status of the heating circuit	x	x	x	x	–	–
Reading the target flow temperature	x	x	x	x	–	–
Reading the pool target flow temperature	–	–	x	–	–	–
Setting the day target flow temperature	–	–	x	x	–	–

Available function	Setting for the Type of circuit function					
	Heating		Pool circuit	Fixed value circuit	Increase in return flow	DHW circuit
	Direct circuit	Mixing circuit				
Setting the set-back target flow temperature	–	–	x	x	–	–
Setting the target return temperature	–	–	–	–	x	–
Setting the domestic hot water	–	–	–	–	–	x
Reading the actual temperature	–	x	x	x	x	–
Reading the current cylinder temperature	–	–	–	–	–	x
Setting the excess temperature	–	x	x	x	–	–
Setting the max limit outs.temp.	x	x	x	x	–	–
Setting the heating curve	x	x	–	–	–	–
Setting the minimum flow temperature for the heating circuit	x	x	–	–	–	–
Setting the maximum flow temperature for the heating circuit	x	x	–	–	–	–
Specifying controller behaviour outside time periods	x	x	–	–	–	–
Activating room temperature modulation	x	x	–	–	–	–
Activating "Cooling possible"	x	x	–	–	–	–
Activating the dew point monitoring	x	x	–	–	–	–
Setting the minimum cooling target flow value	x	x	–	–	–	–
Setting the outdoor temperature at which to end cooling	x	x	–	–	–	–
Setting the dew point offset	x	x	–	–	–	–
Reading the status of the external heat demand	x	x	x	x	–	–
Reading the heating pump status	x	x	x	x	–	–
Reading the status of the heating circuit mixer	–	–	x	x	x	–
Reading the status of the cylinder charging pump	–	–	–	–	–	x

C Connecting the actuators, sensors and sensor assignment for the VR 70 and VR 71

C.1 Legend for connecting the actuators and sensors

Legend point	Meaning	Legend point	Meaning
9e	Domestic hot water generation prioritising diverter valve	FSx	Flow temperature sensor for heating circuit x
BH	Back-up boiler	9kxcl	Heating circuit mixer is closed for heating circuit x, in combination with 9kxop
BufBt	Lower cylinder temperature sensor in a buffer cylinder	9kxop	Heating circuit mixer is open for heating circuit x, in combination with 9kxcl
BufBtDHW	Bottom cylinder temperature sensor for domestic hot water generation in a buffer cylinder (MSS)	3fx	Heating pump for heating circuit x
BufBtHC	Top cylinder temperature sensor for the heating circuit in a buffer cylinder (MSS)	3h	Anti-legionella pump
BufTopDHW	Top cylinder temperature sensor for domestic hot water generation in a buffer cylinder (MSS)	LP/9e	Charging pump or domestic hot water generation prioritising diverter valve
BufTopHC	Bottom cylinder temperature sensor for the heating circuit in a buffer cylinder (MSS)	MA	Multi-function output
COL	Collector temperature sensor	PWM	Control signal for the solar pump station or the feedback signal
COLP	Solar pump	SysFlow	System flow temperature (e.g. in low loss header)
CP	Circulation pump	TD2	Temperature difference sensor 2

Legend point	Meaning	Legend point	Meaning
DEMx	Input for external heat demand for heating circuit x	9g	Diverter valve
DHW1	Cylinder temperature sensor	ZoneOff	2-way valve for switching between zones, in combination with Zone On
DHWBH	Cylinder temperature sensor for the back-up boiler	ZoneOn	2-way valve for switching between zones, in combination with Zone Off
DHWBt	Lower cylinder temperature sensor	9bx	Zone valve for Zone x
DHWoff	2-way valve for switching to cylinder, in combination with DHWOn	Solar Yield	Sensor for the solar yield, installed in the solar circuit return. TD is used to calculate the solar yield between the collector and return sensor
DHWOn	2-way valve for switching to cylinder, in combination with DHWoff	eyield	Sensor for more precise solar yield, installed in the solar circuit flow. TD is used to calculate the solar yield between the flow and return

C.2 Connecting the actuators and sensors to VR 70

Set value	R1	R2	R3/R4	R5/R6	S1	S2	S3	S4	S5	S6	S7
1	3f1	3f2	MA	9k2op/ 9k2cl	DHW1/ BufBt	DEM1	DEM2		SysFlow	FS2	
3	MA	3f2	LP/9e	9k2op/ 9k2cl	BufTop DHW	BufBt DHW	BufBt HC	SysFlow	BufTop HC	FS2	
5	3f1	3f2	9k1op/ 9k1cl	9k2op/ 9k2cl	SysFlow	DEM1	DEM2		FS1	FS2	
6	COLP	3h	MA	9b1	DHW1	DHWBt		SysFlow	COL	Solar Yield	PWM
12	COLP	3f1	9g/9e	9k1op/ 9k1cl	Solar Yield	DHWBt	TD1	TD2	COL	FS1	PWM

C.3 Connecting the actuators to VR 71

Set value	R1	R2	R3	R4	R5	R6	R7/R8	R9/R10	R11/R12
2	3f1	3f2	3f3	MA	COLP1	LP/9e	9k1op/ 9k1cl	9k2op/ 9k2cl	9k3op/ 9k3cl
3	3f1	3f2	3f3	MA		LP/9e	9k1op/ 9k1cl	9k2op/ 9k2cl	9k3op/ 9k3cl
6	3f1	3f2	3f3	MA		LP/9e	9k1op/ 9k1cl	9k2op/ 9k2cl	9k3op/ 9k3cl

C.4 Connecting the sensors to VR 71

Set value	S1	S2	S3	S4	S5	S6	S7	S8	S9	S10	S11	S12
2	SysFlow	FS2	FS3	FS4	DHWTop	DHWBt	COL1	Solar Yield	eyield	TD1	TD2	PWM1
3	SysFlow	FS2	FS3	FS4	BufBt	DEM2	DEM3	DEM4	DHW1			
6	SysFlow	FS2	FS3	FS4	BufTop HC	BufBt HC	BufTop DHW	BufBt DHW	DEM2	DEM3	DEM4	

C.5 VR 70 sensor assignment

Set value	S1	S2	S3	S4	S5	S6
1	VR 10				VR 10	VR 10
3	VR 10	VR 10	VR 10	VR 10	VR 10	VR 10
5	VR 10				VR 10	VR 10
6	VR 10	VR 10		VR 10	VR 11	VR 10
12	VR 10	VR 10	VR 10	VR 10	VR 11	VR 10

C.6 VR 71 sensor assignment

Set value	S1	S2	S3	S4	S5	S6	S7	S8	S9	S10	S11
2	VR 10	VR 10	VR 10	VR 10	VR 10	VR 10	VR 11	VR 10	VR 10	VR 10	VR 10
3	VR 10	VR 10	VR 10	VR 10	VR 10				VR 10		
6	VR 10	VR 10	VR 10	VR 10	VR 10	VR 10	VR 10	VR 10			

D Overview of troubleshooting measures

Troubleshooting

In column 1 in the table, a \$ symbol is displayed after the sensor. The \$ symbol is a placeholder for the sensor number. The % symbol after various components is a placeholder for the address of the component. In both cases, on the display, the system control replaces the symbol with the specific sensor or specific address.

Code/meaning	Possible cause	Measure
Room temp. sensor fault	Room temperature sensor defective	▶ Replace the remote control.
No additional module connection	The cable is defective	▶ Replace the cable.
	Incorrect plug connection	▶ Check the plug connection.
Additional module fault	The cable is defective	▶ Replace the cable.
	Incorrect plug connection	▶ Check the plug connection.
Ventilation unit fault	Ventilation unit fault	▶ See instructions for the ventilation unit.
Ventilation unit connection	The cable is defective	▶ Replace the cable.
	Incorrect plug connection	▶ Check the plug connection.
Communication fault: VR70 %	The cable is defective	▶ Replace the cable.
	Incorrect plug connection	▶ Check the plug connection.
Communication fault: VR71	The cable is defective	▶ Replace the cable.
	Incorrect plug connection	▶ Check the plug connection.
Communication fault: Heat generator %	The cable is defective	▶ Replace the cable.
	Incorrect plug connection	▶ Check the plug connection.
Communication fault: Heat pump %	The cable is defective	▶ Replace the cable.
	Incorrect plug connection	▶ Check the plug connection.
Communication fault: VPM-W	The cable is defective	▶ Replace the cable.
	Incorrect plug connection	▶ Check the plug connection.
Communication fault: VPM-S	The cable is defective	▶ Replace the cable.
	Incorrect plug connection	▶ Check the plug connection.
Communication fault: VMS	The cable is defective	▶ Replace the cable.
	Incorrect plug connection	▶ Check the plug connection.
Sensor fault S \$ VR70 %	Sensor defective	▶ Replace the sensor.
Sensor fault S \$ VR71	Sensor defective	▶ Replace the sensor.
Fault: Heat generator %	Fault in the heat generator	▶ See the instructions for the heat generator displayed.
Fault: Heat pump %	Fault in the heat pump	▶ See the instructions for the heat pump displayed.
Fault: Solar pump %	Fault in the solar pump	▶ Check the solar pump.
Module not supported	Unsuitable module connected, e.g. VR 61 , VR 81	▶ Install a module that the system control supports.
Incorrect configuration: VR70	Incorrect set value for the FM3	▶ Set the correct set value for the FM3.
Incorrect configuration: VR71	Incorrect set value for the FM5	▶ Set the correct set value for the FM5.
System diagram selection incorrect	Incorrectly selected basic system diagram code	▶ Set the correct basic system diagram code.
No remote control for heating circuit %	Missing remote control	▶ Connect the remote control.
No VR70 for this system	Missing FM3	▶ Connect the FM3.
VR71 not supported for this system	FM5 connected in the heating installation	▶ Remove the FM5 from the heating installation.
	Incorrectly selected basic system diagram code	▶ Set the correct basic system diagram code.

Code/meaning	Possible cause	Measure
Hot water temperature sensor S1 not connected	Domestic hot water temperature sensor S1 not connected	▶ Connect the domestic hot water temperature sensor to the FM3.
Incorrect configuration: MA2 VWZ-AI	Incorrectly connected FM3	1. Remove the FM3. 2. Select a suitable configuration.
	Incorrectly connected FM5	1. Remove the FM5. 2. Select another configuration.
Combination of VR70 and VR71 not permitted	VR 70 and VR 71 are connected in combination	▶ Connect either the VR 70 or the VR 71 .
Cascades not supported	Incorrectly selected system diagram	▶ Set the correct system diagram that contains cascades.
Outdoor temperature sensor signal invalid F.521	Outdoor temperature sensor defective	▶ Replace the outdoor temperature sensor.
Incorrect configuration: VR70 % MA	Incorrectly selected setting value for the multi-function output	▶ In the MA VR70, addr. 1 function, set the setting value that is appropriate for the connected component on the FM3's multi-function output.
Incorrect configuration: VR71	Incorrectly selected setting value for the multi-function output	▶ In the MA VR71 function, set the setting value that is appropriate for the connected component on the FM5's multi-function output.
Communication fault: VR91 %	The batteries in the remote control are flat	▶ Change all the batteries (→ Operating and installation instructions for the VR 91f).
	The batteries in the remote control have not been inserted correctly	▶ Insert the batteries in the battery compartment, making sure that the poles are the right way round (→ Operating and installation instructions for the VR 91f).
	The remote control is outside the radio reception range	1. Take the remote control to the radio receiver unit and see if the reception strength increases. 2. If the reception strength is ≤ 4 , find a new installation site for the remote control.
	The remote control is defective	▶ Replace the remote control unit.

Troubleshooting

Symptom	Possible cause	Measure
Display remains dark	The batteries are flat	▶ Change all the batteries (→ Operating instructions, "Changing the batteries").
	The batteries in the system control have not been inserted correctly	▶ Insert the batteries in the battery compartment, making sure that the poles are the right way round.
	The product is defective	▶ Replace the product.
No changes in the display when the rotary knob is turned	Software error	1. Take all the batteries out. 2. Insert the batteries in the battery compartment, making sure that the poles are the right way round.
	The product is defective	▶ Replace the product.
No changes in the display via the selection buttons are pressed	Software error	1. Take all the batteries out. 2. Insert the batteries in the battery compartment, making sure that the poles are the right way round.
	The product is defective	▶ Replace the product.
Heat generator continues to heat once the room temperature has been reached	Incorrect value in the Room temp. mod. or Zone assignment function	1. Set Thermost. or Temp. mod. in the Room temp. mod. function (→ Page 17). 2. In the zone in which the system control is installed, assign the system control's address in Zone assignment (→ Page 18).
	The reception strength is too weak	▶ If the reception strength is ≤ 4 , find a new installation site for the system control.
The heating installation remains in domestic hot water mode	Heat generator cannot reach the max. target flow temperature	▶ Set a lower value in the Max.DHW fl.targ.temp. function (→ Page 20).
Only one of several heating circuits is displayed	Heating circuits inactive	▶ Activate the required heating circuit by defining the functionality in the Type of circuit function (→ Page 15).
Only one of several zones is displayed	Heating circuits inactive	▶ Activate the required heating circuit by defining the functionality in the Type of circuit function (→ Page 15).
	Zone deactivated	▶ Activate the required zone by setting the value to Yes in the Zone activated function (→ Page 17).

Symptom	Possible cause	Measure
Display view: Clean outside temperature sensor	The battery in the outdoor temperature sensor is flat	► Clean the solar cell of the outdoor temperature sensor (→ Operating instructions, "Cleaning the outdoor temperature sensor").
	The reception strength of the outdoor temperature sensor is weak or non-existent	► If the reception strength is ≤ 4 , find a new installation site for the outdoor temperature sensor.
	The product is defective	► Replace the product.
Display view: No RF communication	No power supply to the radio receiver unit	► Reconnect the power supply to the radio receiver unit.
	The system control is outside the radio reception range	1. Take the system control to the radio receiver unit and see if the reception strength increases. 2. If the reception strength is ≤ 4 , find a new installation site for the system control.
	The product is defective	► Replace the product.
It is not possible to switch to the installer level	You do not know the code for the installer level	► Reset the system control to the factory settings (→ Page 10).

E Maintenance messages

The maintenance message **Service heat pump 1** is an example of a maintenance message that may appear for heat pumps 1 to 6.

The maintenance message **Service heat generator 1** is an example of a maintenance message that may appear for heat generators 1 to 6.

#	Code/meaning	Description	Maintenance work	Interval	
1	Service heat pump 1	The heat pump requires maintenance work.	Refer to the operating or installation instructions for the relevant heat pump for information on the maintenance work required	See the operating or installation instructions for the heat pump	
2	Service heat generator 1	The heat generator requires maintenance work.	Refer to the operating or installation instructions for the relevant heat generator for information on the maintenance work required	See the operating or installation instructions for the heat generator	
3	Service ventilation unit	The ventilation unit requires maintenance work.	Refer to the operating or installation instructions for the relevant ventilation unit for information on the maintenance work required	See the operating or installation instructions for the ventilation unit	
4	Service date Next service on	Date on which maintenance is due for the heating installation.	Carry out the required maintenance work	Date entered in the control	

Index

A	
Activating automatic cooling	11
Activating cooling	17
Activating Room temp. mod.	17
Activating Solar pump boost	20
Activating Source regeneration	12
Activating the actuation reversal for the cascade	13
Activating the actuation sequence for the cascade	13
Activating the adaptive heating curve	11
Activating the cylinder charging	19
Activating the dew point monitoring	17
Activating the parallel cylinder charging	19
Activating the screed-drying function	22
Air quality sensor, setting the maximum value	22
Assigning a zone	18
Assigning a zone to the remote control unit	18
Assigning the system control to a zone	18
Attaching the unit mounting bracket, to the wall	8
Attaching, system control to the unit mounting bracket	8
Auxiliary heater, setting the output	14
B	
Basic system diagram configuration	13, 27
Bottom cylinder temperature sensor, reading the value	21
Buffer cylinder for the heating circuit, offset for charging	13
C	
CE marking	5
Changing the batteries	24
Changing the code, installer level	23
Circulation pump, reading the status	18
Competent person	4
Configuring the basic system diagram	13, 27
Configuring the heating circuit	11
Configuring the multi-function input	14
Configuring the multi-function output	14
Configuring the VR 70	13
Configuring the VR 70's multi-function output	14
Configuring the VR 71	13
Configuring the VR 71's multi-function output	14
Connecting the radio receiver unit to the heat generator	9
Connecting the radio receiver unit to the ventilation unit	9
Cooling, setting the target flow temperature	15
Cylinder charging pump, reading the status	18
Cylinder charging, setting the hysteresis	19
Cylinder, setting the maximum charging time	19
D	
Deactivating the zone	17
Deactivating units	13
Defining the anti-legionella function, day	18
Defining the anti-legionella function, time	19
Defining the basic system diagram	13
Defining the boiler type	12
Defining the hybrid manager	12
Defining the offset, domestic hot water cylinder charging	19
Defining the overrun time, cylinder pump	19
Defining the switch-off differential, second differential temperature control	21
Defining the switch-off differential, solar charging	21
Defining the switch-on differential, second differential temperature control	21
Defining the switch-on differential, solar charging	21
Defining the temperature of the solar cylinder	21
Deleting personal data	25
Determining the installation site of the outdoor temperature sensor	6
Determining the reception strength of the outdoor temperature sensor	6
Determining the reception strength of the outdoor temperature sensor, requirements	6
Determining the signal strength of the outdoor temperature sensor	6
Determining the system control's installation site	8
Determining the system control's reception strength	8
Determining the system control's signal strength	8
Dew point, setting the offset	17
Differential temperature control, reading the status	22
Differential temperature sensor 1, reading the value	21
Differential temperature sensor 2, reading the value	21
Displaying fault messages, list	23
Disposal, outdoor temperature sensor	24
Disposing of batteries	25
Disposing of the outdoor temperature sensor	24
Disposing of the outdoor temperature sensor if defective	24
Disposing of the product	25
Documents	5
Domestic hot water cylinder charging, defining the offset	19
Domestic hot water cylinder, reading the actual temperature	18
Domestic hot water cylinder, setting the set target temperature	18
E	
Entering contact details	11
Entering the service date	11
F	
Fitting the outdoor temperature sensor	7
Fitting the system control, to the unit mounting bracket	8
Fitting, outdoor temperature sensor to the wall base	7
Fitting, system control to the unit mounting bracket	8
Frost	4
H	
Handing over	23
Heat generator, connecting the radio receiver unit	9
Heating circuit mixer, reading the status	17
Heating circuit type configuration	15
Heating circuit type system configuration	15
Heating installation, starting up	9
Heating pump, reading the status	17
Hot water demand, setting the anti-cycling time	19
I	
Installer level, changing the code	23
Installing the radio receiver unit, on the wall	6
Installing, radio receiver unit on the wall	6
Intended use	4
L	
Lines, maximum length	5
Lines, minimum cross-section	5
Lines, selecting	5
M	
Maintenance message	23
N	
Nomenclature	5
O	
Operating and display functions	10
Outdoor temperature sensor reception strength, requirements	6
Outdoor temperature sensor, determining the installation site	6

Outdoor temperature sensor, reading the reception strength	22	Reading the zone valve status	18
Outdoor temperature sensor, reception strength requirements	6	Reception strength, reading the outdoor temperature sensor	22
P		Reception strength, reading the system control	22
Polarity	9	Recycling/disposing of packaging	25
Preparatory work for starting up the heating installation	9	Regulations	4
Preparatory work for system start-up	9	Replacing the outdoor temperature sensor	24
Preparatory work, starting up the heating installation	9	Replacing, outdoor temperature sensor	24
Preparatory work, starting up the system	9	Resetting the running time, solar pump	20
Q		Resetting the set values	10
Qualification	4	Resetting the values	10
R		Resetting times	10
Reading the actual temperature, domestic hot water cylinder	18	Resetting to the factory settings	10
Reading the actuation sequence for the cascade	13	S	
Reading the air quality sensor	22	Second differential temperature control, defining the switch-off differential	21
Reading the back-up boiler's status	14	Second differential temperature control, defining the switch-on differential	21
Reading the bottom cylinder temperature for domestic hot water	19	Selecting the back-up boiler support	13
Reading the bottom cylinder temperature for heating	20	Selecting the wiring centre for the actuator test	22
Reading the bottom cylinder temperature for the buffer cylinder	19	Selecting the wiring centre, actuator test	22
Reading the collector temperature	20	Selecting the wiring centre, sensor test	22
Reading the current dew point	12	Sensor test, selecting the wiring centre	22
Reading the current flow rate	21	Setting End OT cooling	17
Reading the current flow temperature for the additional module	14	Setting Start OT cooling	11
Reading the current flow temperature for the heat generator	14	Setting the alternative point	12
Reading the current flow temperature for the heat pump	14	Setting the anti-cycling time, hot water demand	19
Reading the dew point	12	Setting the collector temperature	20
Reading the domestic hot water circuit's flow temperature	18	Setting the cooling start temperature	11
Reading the fault status	11	Setting the cooling stop temperature	17
Reading the heat generator's status	14	Setting the cylinder	18
Reading the heat pump's status	14	Setting the day target flow temperature	15
Reading the heating circuit's actual temperature	15	Setting the day temperature	17
Reading the heating circuit's flow temperature	15	Setting the domestic hot water bivalence point	12
Reading the room air humidity	12	Setting the domestic hot water target flow temperature	20
Reading the room temperature	18	Setting the excess temperature	15
Reading the running time, solar pump	20	Setting the flow rate, solar circuit	20
Reading the software version	11	Setting the frost protection delay	11
Reading the status		Setting the heating bivalence point	12
Circulation pump	18	Setting the heating curve	16
Cylinder charging pump	18	Setting the hysteresis, cylinder charging	19
Heating circuit mixer	17	Setting the maximum charging time, cylinder	19
Heating pump	17	Setting the maximum target flow temperature	16
Solar pump	20	Setting the maximum temperature	21
Reading the status of the external heat demand	17	Setting the minimum target flow temperature	16
Reading the status of the heating circuit	15	Setting the minimum temperature	21
Reading the status, differential temperature control	22	Setting the offset for charging the buffer cylinder for the heating circuit	13
Reading the swimming pool flow temperature	15	Setting the offset, dew point	17
Reading the system status	11	Setting the OT constant heating	11
Reading the top cylinder temperature for domestic hot water	19	Setting the output, auxiliary heater	14
Reading the top cylinder temperature for heating	19	Setting the purging time	20
Reading the top cylinder temperature for the buffer cylinder	19	Setting the set-back target flow temperature	15
Reading the value, bottom cylinder temperature sensor	21	Setting the set-back temperature	17
Reading the value, differential temperature sensor 1	21	Setting the solar circuit protection	20
Reading the value, differential temperature sensor 2	21	Setting the switch-off threshold	16
Reading the value, solar yield sensor	20	Setting the target cylinder temperature, domestic hot water cylinder	18
Reading the value, system flow temperature	13	Setting the target flow temperature, cooling	15
Reading the water pressure	11	Setting the target flow temperature, maximum	16
		Setting the target flow temperature, minimum	16
		Setting the target return temperature	15
		Setting the temperature for limp home mode	12
		Setting the temperature when the heat pump fails	12

Setting the temperature, day	17
Setting the temperature, set-back	17
Setting Type of circuit	15
Solar charging, defining the switch-off differential.....	21
Solar charging, defining the switch-on differential.....	21
Solar circuit, setting the flow rate	20
Solar pump, reading the running time	20
Solar pump, reading the status	20
Solar pump, resetting the running time	20
Solar yield sensor, reading the value	20
Spare parts.....	23
Specifying the controller behaviour	16
Starting up the heating installation	9
Starting up the outdoor temperature sensor.....	7
Starting up the product.....	9
Starting up, outdoor temperature sensor.....	7
Start-up.....	9
Start-up, preparatory work.....	9
System control, determining the installation site	8
System control, reading the reception strength.....	22
System flow temperature, reading the value	13
System start-up	9
T	
Tool	4
Z	
Zone activated.....	17
Zone assignment.....	18

Supplier

Vaillant Ltd.

Nottingham Road ■ Belper ■ Derbyshire ■ DE56 1JT

Telephone 0330 100 3143

info@vaillant.co.uk ■ www.vaillant.co.uk



0020237057_02

Publisher/manufacture

Vaillant GmbH

Berghauser Str. 40 ■ D-42859 Remscheid

Tel. +49 2191 18 0 ■ Fax +49 2191 18 2810

info@vaillant.de ■ www.vaillant.de

© These instructions, or parts thereof, are protected by copyright and may be reproduced or distributed only with the manufacturer's written consent.

Subject to technical modifications.