

aroTHERM plus

VWL 35/6 A 230V S2 ... VWL 75/6 A S2

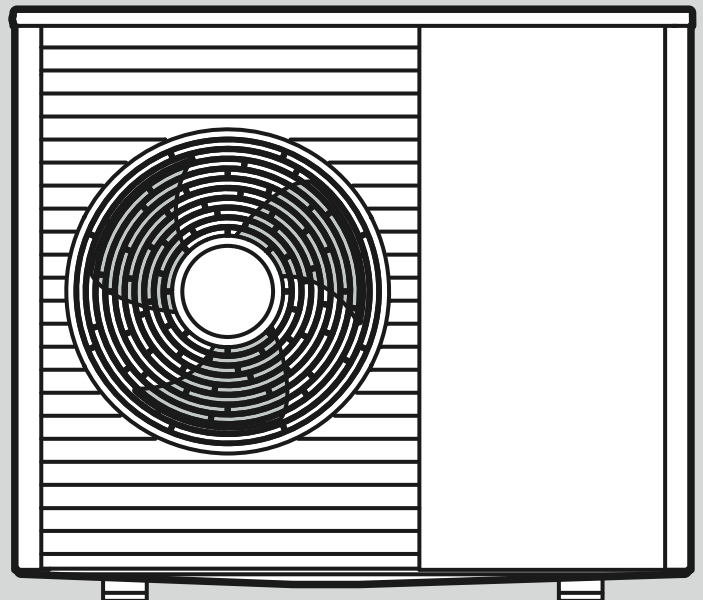

en	Operating instructions	3
en	Installation and maintenance instructions.....	11

Operating instructions

Contents

1	Safety	4
1.1	Intended use	4
1.2	General safety information	4
2	Notes on the documentation	6
2.1	Documents.....	6
2.2	Validity of the instructions	6
3	Product description	6
3.1	Heat pump system.....	6
3.2	Description of the product.....	6
3.3	Functions of the heat pump	6
3.4	System separation and frost protection	6
3.5	Product design.....	6
3.6	Data plate and serial number	6
3.7	Warning sticker	6
4	Protective zone	7
4.1	Protective zone	7
4.2	Design of the condensate discharge	8
5	Operation	9
5.1	Switching on the product	9
5.2	Operating the product.....	9
5.3	Guaranteeing frost protection	9
5.4	Switching off the product	9
6	Care and maintenance	9
6.1	Keeping the product clear.....	9
6.2	Cleaning the product.....	9
6.3	Carrying out maintenance work.....	9
7	Troubleshooting	9
7.1	Eliminating faults.....	9
8	Decommissioning	9
8.1	Temporarily decommissioning the product.....	9
8.2	Permanently decommissioning the product.....	9
9	Recycling and disposal	10
9.1	Arranging disposal of refrigerant	10
10	Guarantee and customer service	10
10.1	Guarantee.....	10
10.2	Customer service.....	10



1 Safety

1.1 Intended use

There is a risk of injury or death to the user or others, or of damage to the product and other property in the event of improper use or use for which it is not intended.

The product is the outdoor unit of an air-to-water heat pump with monoblock design.

The product uses the outdoor air as a heat source and can be used to heat a residential building and for domestic hot water generation.

The air that escapes from the product must be able to flow out freely, and must not be used for any other purposes.

The product is only intended for outdoor installation.

The product is intended exclusively for domestic use.

Intended use includes the following:

- observance of the operating instructions included for the product and any other installation components
- compliance with all inspection and maintenance conditions listed in the instructions.

This product can be used by children aged from 8 years and above and persons with reduced physical, sensory or mental capabilities or lack of experience and knowledge if they have been given supervision or instruction concerning use of the product in a safe way and understand the hazards involved. Children must not play with the product. Cleaning and user maintenance work must not be carried out by children unless they are supervised.

Any other use that is not specified in these instructions, or use beyond that specified in this document, shall be considered improper use. Any direct commercial or industrial use is also deemed to be improper.

Caution.

Improper use of any kind is prohibited.

1.2 General safety information

1.2.1 Risk of death caused by fire or explosion if there is a leak in the refrigerant circuit

The product contains the combustible refrigerant R290. In the event of a leak, escaping refrigerant may mix with air to form a flammable atmosphere. There is a risk of fire and explosion.

A protective zone is defined for the area close around the product. See section "Protective zone".

- ▶ Ensure that there are no ignition sources, such as plug sockets, light switches, lamps, electrical switches or other permanent ignitions sources, in the protective zone.
- ▶ Do not use any sprays or other combustible gases in the protective zone.

1.2.2 Risk of death due to changes to the product or the product environment

- ▶ Never remove, bridge or block the safety devices.
- ▶ Do not tamper with any of the safety devices.
- ▶ Do not damage or remove any tamper-proof seals on components.
- ▶ Do not make any changes:
 - The product itself
 - To the supply lines
 - On the drain pipework
 - On the expansion relief valve for the heat source circuit
 - to constructional conditions that may affect the operational reliability of the product

1.2.3 Risk of injury and material damage due to maintenance and repairs carried out incorrectly or not carried out at all

- ▶ Never attempt to carry out maintenance work or repairs on your product yourself.
- ▶ Faults and damage should be immediately eliminated by a competent person.
- ▶ Adhere to the maintenance intervals specified.





1.2.4 Risk of material damage caused by frost

- ▶ Ensure that the heating installation always remains in operation during freezing conditions and that all rooms are sufficiently heated.
- ▶ If you cannot ensure the operation, have a competent person drain the heating installation.

1.2.5 Danger caused by improper operation

Improper operation may present a danger to you and others, and cause material damage.

- ▶ Carefully read the enclosed instructions and all other applicable documents, particularly the "Safety" section and the warnings.
- ▶ Only carry out the activities for which instructions are provided in these operating instructions.



2 Notes on the documentation

2.1 Documents

- ▶ Always observe all operating instructions enclosed with the installation components.
- ▶ Store these instructions and all other applicable documents for further use.

2.2 Validity of the instructions

These instructions apply only to:

Product
VWL 35/6 A 230V S2
VWL 55/6 A 230V S2
VWL 75/6 A 230V S2

3 Product description

3.1 Heat pump system

Design of a typical heat pump system with monoblock technology:

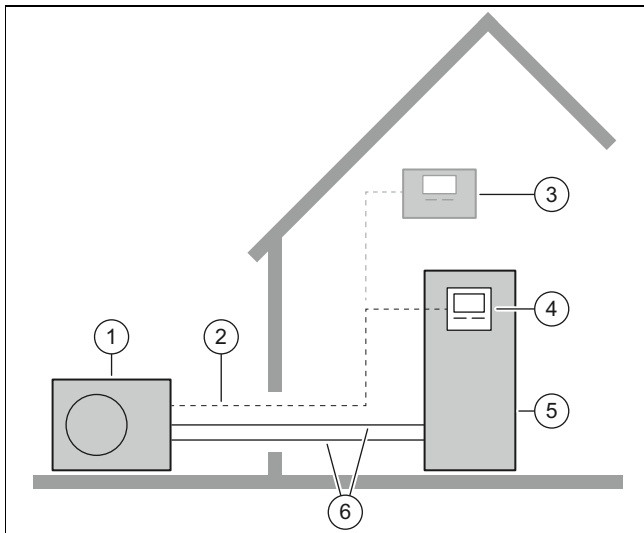

- | | |
|-------------------------------|--|
| 1 Outdoor unit | 5 Indoor unit with domestic hot water cylinder |
| 2 eBUS line | 6 Heating circuit |
| 3 Optional system control | |
| 4 Control for the indoor unit | |

3.2 Description of the product

The product is the outdoor unit of an air-to-water heat pump with monoblock technology.

3.3 Functions of the heat pump

The heat pump has a closed refrigerant circuit in which refrigerant circulates.

Cyclic evaporation, compression, liquefaction and expansion takes in heat energy from the surroundings and transfers it to the building. In cooling mode, heat energy is extracted from the building and released into the environment.

3.4 System separation and frost protection

With a system separation, an intermediate heat exchanger is installed in the indoor unit. This separates the heating circuit into a primary heating circuit (to the outdoor unit) and a secondary heating circuit (in the building).

If the primary heating circuit is filled with a water/frost protection mixture (brine fluid), the outdoor unit is then protected against freezing, even if this is electrically switched off or in the case of a power cut.

3.5 Product design

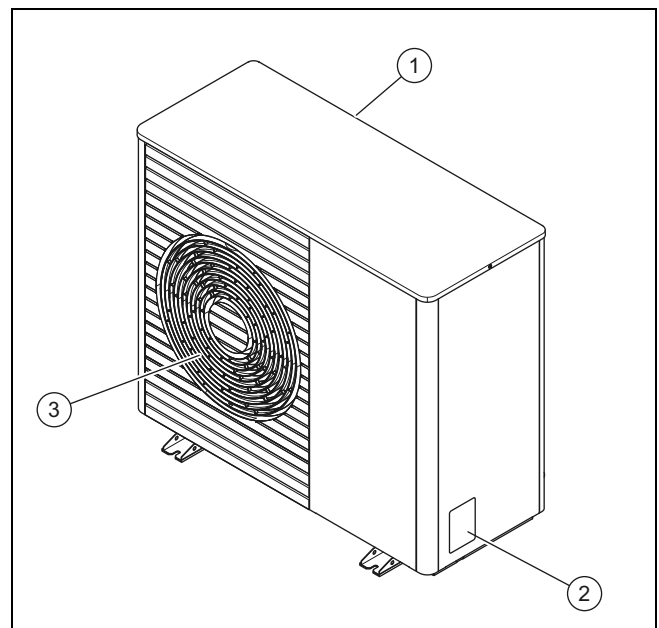

- | | |
|--------------------|---------------------|
| 1 Air inlet grille | 3 Air outlet grille |
| 2 Data plate | |

3.6 Data plate and serial number

The data plate is located on the right-hand side of the product's exterior.

The data plate includes the nomenclature and the serial number.

3.7 Warning sticker

Safety-relevant stickers are affixed to several points on the product. The warning stickers include rules of conduct for the R290 refrigerant. The warning stickers must not be removed.

Symbol	Meaning
R290	Warning against flammable materials in conjunction with R290 refrigerant.
	Fire, naked flames and smoke are prohibited.

Symbol	Meaning
	Read the service information and technical instructions.

4 Protective zone

4.1 Protective zone

The product contains R290 refrigerant. Note that this refrigerant has a higher density than air. In the event of a leak, escaping refrigerant may collect near the ground.

The refrigerant must not collect in any way that may lead to a dangerous, explosive, suffocating or toxic atmosphere. The refrigerant must not get inside the building via building openings. The refrigerant must not collect in grooves.

A protective zone is defined around the product. There must be no windows, doors, light shafts, cellar entrances, escape hatches, flat-roof windows or ventilation openings in the protective zone.

There must be no ignition sources, such as plug sockets, light switches, lamps, electrical switches or other permanent ignition sources, in the protective zone.

The protective zone must not extend to adjacent buildings or public traffic areas.

In the protective zone, you are not permitted to make any subsequent structural alterations which infringe the stated rules for the protective zone.

4.1.1 Protective zone for ground installation on the premises

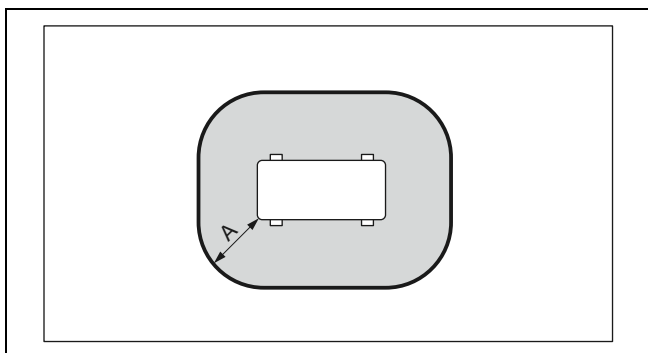

A 1000 mm

4.1.2 Protective zone for ground installation in front of a building wall

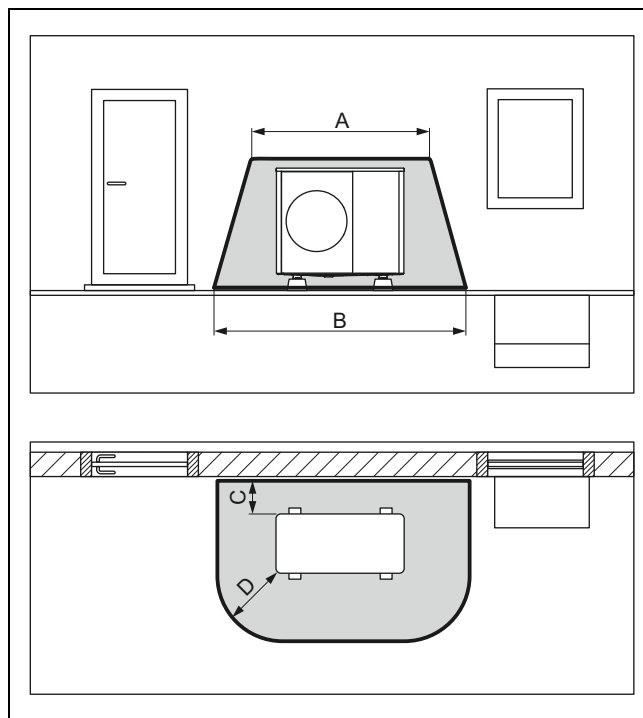

A 2100 mm

C 200 mm/250 mm

B 3100 mm

D 1000 mm

4.1.3 Protective zone for ground installation in a building corner

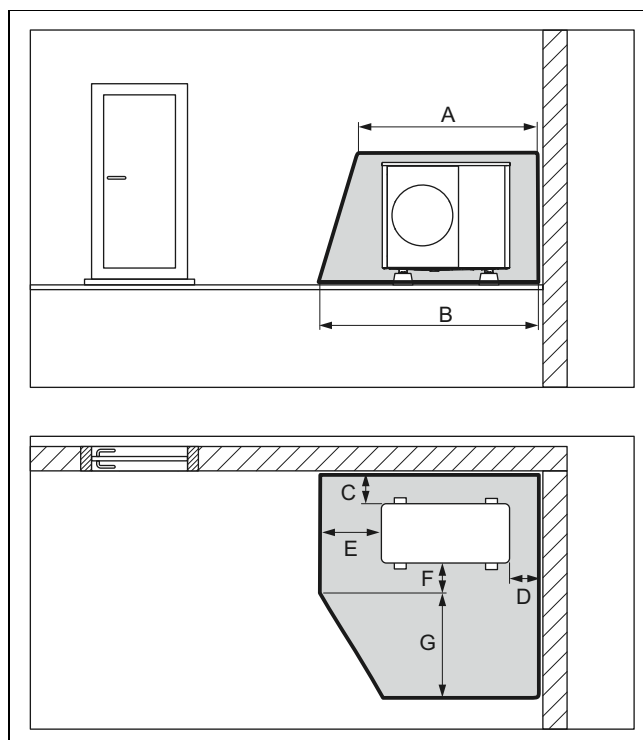

A 2100 mm

E 1000 mm

B 2600 mm

F 500 mm

C 200 mm/250 mm

G 1800 mm

D 500 mm

4.1.4 Protective zone for wall installation in front of a building wall

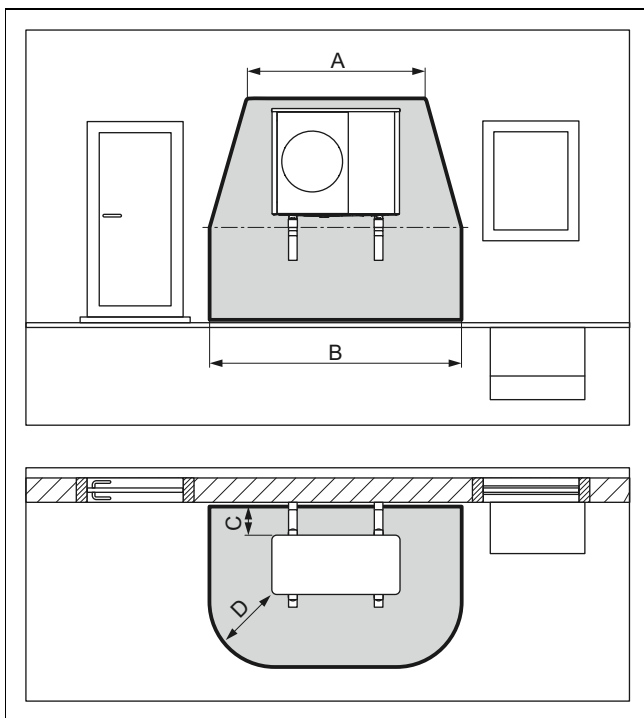

A	2100 mm	C	200 mm/250 mm
B	3100 mm	D	1000 mm

The protective zone below the product extends as far as the floor.

4.1.5 Protective zone for wall installation in a building corner

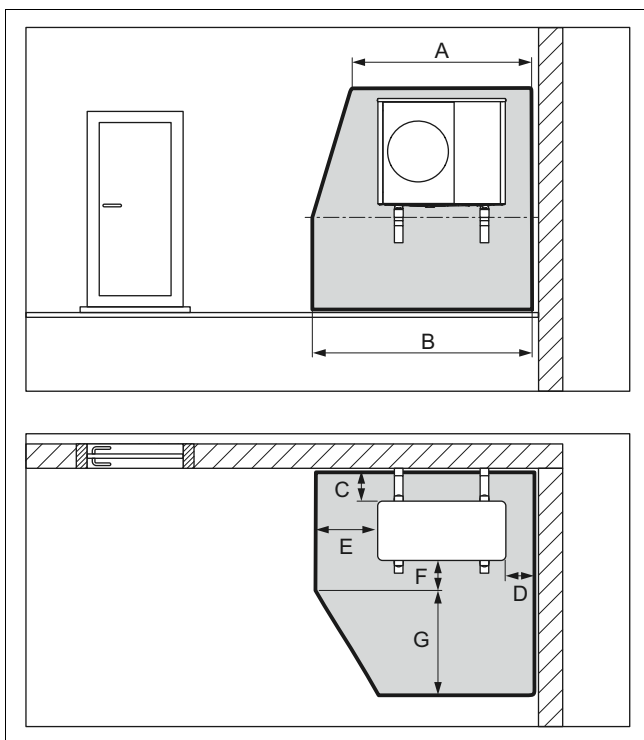

A	2100 mm	E	1000 mm
B	2600 mm	F	500 mm
C	200 mm/250 mm	G	1800 mm
D	500 mm		

The protective zone below the product extends as far as the floor.

4.1.6 Protective zone for flat-roof installation

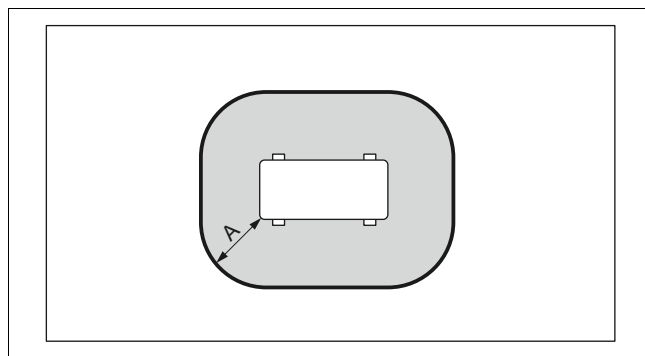

A 1000 mm

4.2 Design of the condensate discharge

The condensate that accumulates can be guided into a sewer, pump sump or soakaway via a downpipe, gully, balcony run-off or roof run-off. Open gullies or downpipes within the protective zone do not pose any safety risk.

For all installation types, you must ensure that any condensate that accumulates is discharged frost-free.

4.2.1 Design of the condensate discharge for ground installation

For the ground installation, the condensate must be discharged via a downpipe into a gravel bed which is located in the frost-free area.

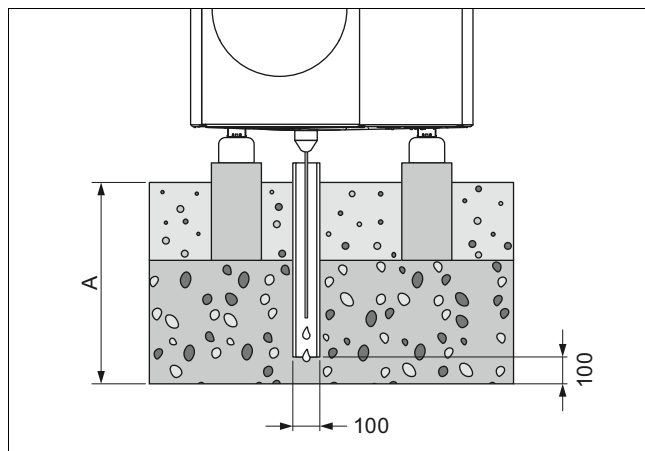

For a region with ground frost, dimension A is ≥ 900 mm and, for a region without ground frost, it is ≥ 600 mm.

The downpipe must flow into a sufficiently large gravel bed so that the condensate can trickle away freely.

To prevent the condensate from freezing, the heating wire must be threaded into the downpipe via the condensate discharge tundish.

4.2.2 Design of the condensate discharge for wall installation

For wall installation, the condensate can be discharged into a gravel bed that is located below the product.

Alternatively, the condensate can be discharged by connecting the condensate discharge pipe to a downpipe. In this case, depending on the local conditions, you must use

electrical trace heating in order to keep the condensate discharge pipe frost-free.

4.2.3 Design of the condensate discharge for flat-roof installation

For flat-roof installation, the condensate can be discharged by connecting a condensate discharge pipe to a downpipe or a roof run-off. In this case, depending on the local conditions, you must use electrical trace heating in order to keep the condensate discharge pipe frost-free.

5 Operation

5.1 Switching on the product

- ▶ Switch on all of the disconnectors to which the product is connected in the building.

5.2 Operating the product

It is operated via the indoor unit's control (→ Operating instructions for the indoor unit) and via the optional system control (→ Operating instructions for the system control).

5.3 Guaranteeing frost protection

1. If no system separation for guaranteeing the frost protection is present, ensure that the product is switched on and remains switched on.
2. Ensure that no snow accumulates around the air inlet grille and air outlet grille.

5.4 Switching off the product

1. Switch off all of the disconnectors to which the product is connected in the building.
2. Note that this means that frost protection is no longer guaranteed if no system separation for guaranteeing the frost protection is present.

6 Care and maintenance

6.1 Keeping the product clear

1. Regularly remove branches and leaves that have gathered around the product.
2. Regularly remove leaves and dirt from the ventilation grille below the product.
3. Regularly remove snow from the air inlet grille and from the air outlet grille.
4. Regularly remove snow that has gathered around the product.

6.2 Cleaning the product

1. Clean the casing with a damp cloth and a little solvent-free soap.
2. Do not use sprays, scouring agents, detergents, solvents or cleaning agents that contain chlorine.

6.3 Carrying out maintenance work



Danger!

Risk of injury and risk of material damage due to neglected or incorrect maintenance and repairs.

Neglected or incorrect maintenance work or repairs may lead to personal injury or damage to the product.

- ▶ Never attempt to carry out maintenance work or repairs on the product.
- ▶ Employ an authorised installation company to complete such work. We recommend making a maintenance contract.

7 Troubleshooting

7.1 Eliminating faults

- ▶ If you observe a cloud of vapour on the product, you do not have to do anything. This effect may arise during the thawing process.
- ▶ If the product will no longer start up, check whether the power supply is interrupted. If required, switch on all of the disconnectors to which the product is connected in the building.
- ▶ Contact a competent person if the measure that is described is unsuccessful.

8 Decommissioning

8.1 Temporarily decommissioning the product

1. Switch off all of the disconnectors to which the product is connected in the building.
2. Protect the heating installation against frost.

8.2 Permanently decommissioning the product

- ▶ Have a competent person permanently decommission the product.

9 Recycling and disposal

Disposing of the packaging

- ▶ The competent person who installed your product is responsible for the disposal of the packaging.

Disposing of the product



■ If the product is labelled with this mark:

- ▶ In this case, do not dispose of the product with the household waste.
- ▶ Instead, hand in the product to a collection centre for waste electrical or electronic equipment.

Disposing of batteries



■ If the product contains batteries that are labelled with this mark:

- ▶ In this case, dispose of the batteries at a collection point for batteries.
 - ◁ **Prerequisite:** The batteries can be removed from the product without causing any destruction. Otherwise, the batteries are disposed of together with the product.
- ▶ In accordance with the legal regulations, used batteries must be returned since batteries may contain substances that are harmful to health and the environment.

9.1 Arranging disposal of refrigerant

The product is filled with R290 refrigerant.

- ▶ Refrigerant must only be disposed of by an authorised competent person.
- ▶ Observe the general safety information.

10 Guarantee and customer service

10.1 Guarantee

Vaillant provides a full parts and labour guarantee for this appliance for the duration as shown on the enclosed registration card which must be fully completed and returned within 30 days of installation. All appliances must be installed by a suitably competent person fully conversant and in accordance with all current regulations applicable to the appliance type installation. In the case of gas appliances the Gas Safety (Installation and Use) Regulations 1998, and the manufacturer's instructions. In the UK competent persons approved at the time by the Health and Safety Executive undertake the work in compliance with safe and satisfactory standards. Installers should also be fully conversant with and competent with all necessary electrical and building regulations that may apply to the installation.

In addition all unvented domestic hot water cylinders must be installed by a competent person to the prevailing building regulations at the time of installation (G3). All appliances shall be fully commissioned in accordance with our installation manual and Benchmark commissioning check list (this will be included within the installation manual). These must be signed and given to the user for safe keeping during the hand over process. Installers should also at this time advise the user of the annual servicing requirements and advise of appropriate service agreement.

Terms and conditions do apply to the guarantee, details of which can be found on the registration card included with this appliance. In order to qualify for guarantee after one year the appliance must be serviced in accordance with our installation manual servicing instructions. The benchmark service history should be completed. Note - all costs associated with this service are excluded from this guarantee.

Failure to install and commission this appliance in compliance with the manufacturer's instructions will invalidate the guarantee (this does not affect the customer's statutory rights).

10.2 Customer service

For contact details for our customer service department, you can write to the address that is provided on the back page, or you can visit www.vaillant.co.uk.

Installation and maintenance instructions

Contents

1	Safety	13	6.6	Connecting the pipelines to the product	29
1.1	Intended use	13	6.7	Completing the hydraulics installation	29
1.2	General safety information	13	6.8	Option: Connecting the product to a swimming pool	29
1.3	Regulations (directives, laws, standards)	14	7	Electrical installation	29
2	Notes on the documentation	15	7.1	Preparing the electrical installation	30
2.1	Documents	15	7.2	Requirements for the quality of the mains voltage	30
2.2	Validity of the instructions	15	7.3	Requirements for electrical components	30
2.3	Further information	15	7.4	Requirements for the eBUS line	30
3	Product description	15	7.5	Electrical partition	30
3.1	Heat pump system	15	7.6	Installing components for the energy supply company lockout function	30
3.2	Description of the product	15	7.7	Removing the cover for the electrical connections	30
3.3	Cooling mode	15	7.8	Stripping the electrical wire	31
3.4	Noise reduction mode	15	7.9	Establishing the power supply, 1~/230V	31
3.5	Functions of the heat pump	15	7.10	Connecting the eBUS line	31
3.6	Product design	16	7.11	Connecting a limit thermostat	32
3.7	Information on the data plate	17	7.12	Connecting accessories	32
3.8	Connection symbols	18	7.13	Installing the cover for the electrical connections	32
3.9	Warning sticker	18	8	Start-up	32
3.10	CE marking	18	8.1	Checking before switching on	32
3.11	Benchmark	18	8.2	Switching on the product	32
3.12	Application limits	18	8.3	Checking and treating the heating water/filling and supplementary water	32
3.13	Thawing mode	19	8.4	Filling and purging the heating circuit	33
3.14	Safety devices	19	8.5	Available remaining feed pressure	33
4	Protective zone	19	9	Handing over to the end user	33
4.1	Protective zone	19	9.1	Instructing the end user	33
4.2	Design of the condensate discharge	21	10	Troubleshooting	34
5	Set-up	22	10.1	Fault messages	34
5.1	Checking the scope of delivery	22	10.2	Other faults	34
5.2	Transporting the product	22	11	Inspection and maintenance	34
5.3	Dimensions	22	11.1	Preparing for inspection and maintenance	34
5.4	Complying with minimum clearances	23	11.2	Observing the work plan and intervals	34
5.5	Conditions for the installation type	23	11.3	Procuring spare parts	34
5.6	Selecting the installation site	23	11.4	Carrying out maintenance work	34
5.7	Preparing for fitting and installation	24	11.5	Completing inspection and maintenance	35
5.8	Planning the foundation	25	12	Repair and service	35
5.9	Creating a foundation	25	12.1	Preparing repair and service work on the refrigerant circuit	35
5.10	Guaranteeing occupational safety	25	12.2	Removing refrigerant from the product	36
5.11	Installing the product	25	12.3	Removing components of the refrigerant circuit	36
5.12	Connecting the condensate discharge pipe	26	12.4	Installing components of the refrigerant circuit	36
5.13	Setting up a protective wall	27	12.5	Filling the product with refrigerant	36
5.14	Removing/installing the casing sections	27	12.6	Completing repair and service work	37
6	Hydraulics installation	28	13	Decommissioning	37
6.1	Installation type: Direct connection or system separation	28	13.1	Temporarily decommissioning the product	37
6.2	Guaranteeing the minimum circulation water volume	28	13.2	Permanently decommissioning the product	37
6.3	Requirements for hydraulic components	28	14	Recycling and disposal	38
6.4	Preparing the hydraulics installation	28	14.1	Disposing of the packaging	38
6.5	Routing pipelines to the product	28	14.2	Disposing of the refrigerant	38

15	Customer service	38
15.1	Customer service.....	38
	Appendix	39
A	Functional diagram	39
B	Safety devices	40
C	Wiring diagram	41
C.1	Wiring diagram, power supply, 1~/230V	41
C.2	Wiring diagram, sensors and actuators	42
D	Inspection and maintenance work	43
E	Technical data	43
F	Commissioning Checklist	47
	Index	50

1 Safety

1.1 Intended use

There is a risk of injury or death to the user or others, or of damage to the product and other property in the event of improper use or use for which it is not intended.

The product is the outdoor unit of an air-to-water heat pump with monoblock design.

The product uses the outdoor air as a heat source and can be used to heat a residential building and for domestic hot water generation.

The air that escapes from the product must be able to flow out freely, and must not be used for any other purposes.

The product is only intended for outdoor installation.

The product is intended exclusively for domestic use.

Intended use includes the following:

- observance of accompanying operating, installation and maintenance instructions for the product and any other system components
- installing and setting up the product in accordance with the product and system approval
- compliance with all inspection and maintenance conditions listed in the instructions.

Intended use also covers installation in accordance with the IP code.

Any other use that is not specified in these instructions, or use beyond that specified in this document, shall be considered improper use. Any direct commercial or industrial use is also deemed to be improper.

Caution.

Improper use of any kind is prohibited.

1.2 General safety information

1.2.1 Risk caused by inadequate qualifications

The following work must only be carried out by competent persons who are sufficiently qualified to do so:

- Set-up
 - Dismantling
 - Installation
 - Start-up
 - Inspection and maintenance
 - Repair
 - Decommissioning
- ▶ Proceed in accordance with current technology.

1.2.2 Risk caused by inadequate qualifications for the R290 refrigerant

Any activity that requires the unit to be opened must only be carried out by competent persons who have knowledge about the particular properties and risks of R290 refrigerant.

Specific expert refrigeration knowledge in compliance with the local laws is required when carrying out work on the refrigerant circuit. This also includes specialist knowledge about handling flammable refrigerants, the corresponding tools and the required personal protective equipment.

- ▶ Comply with the corresponding local laws and regulations.

1.2.3 Risk of death from electric shock

There is a risk of death from electric shock if you touch live components.

Before commencing work on the product:

- ▶ Disconnect the product from the power supply by switching off all power supplies at all poles (electrical partition in over-voltage category III for full partition, e.g. fuse or circuit breaker).
- ▶ Secure against being switched back on again.
- ▶ Wait for at least 3 minutes until the capacitors have discharged.
- ▶ Check that there is no voltage.



1.2.4 Risk of death caused by fire or explosion if there is a leak in the refrigerant circuit

The product contains the combustible refrigerant R290. In the event of a leak, escaping refrigerant may mix with air to form a flammable atmosphere. There is a risk of fire and explosion.

A protective zone is defined for the area close around the product. See section "Protective zone".

- ▶ If you are working on the product when it is open, before starting work, use a gas sniffer to ensure that there is no leak.
- ▶ The gas sniffer itself must not be an ignition source. The gas sniffer must be calibrated to R290 refrigerant and set to $\leq 25\%$ of the lower explosive limit.
- ▶ Keep all ignition sources away from the protective zone. In particular, open flames, hot surfaces with temperatures above 370 °C, electrical devices or tools that are not free from electrical sources, static discharges.

1.2.5 Risk of death caused by fire or explosion when removing the refrigerant

The product contains the combustible refrigerant R290. The refrigerant may mix with air to form a flammable atmosphere. There is a risk of fire and explosion.

- ▶ Only carry out the work if you are competent at handling R290 refrigerant.
- ▶ Wear suitable personal protective equipment and bring a fire extinguisher with you.
- ▶ Only use tools and units that are permitted for R290 refrigerant and are in proper working condition.
- ▶ Ensure that no air gets into the refrigerant circuit, into refrigerant-carrying tools or units, or into the refrigerant cylinder.
- ▶ Note that the refrigerant R290 must never be introduced into the sewage system.

1.2.6 Risk of death due to lack of safety devices

The basic diagrams included in this document do not show all safety devices required for correct installation.

- ▶ Install the necessary safety devices in the installation.
- ▶ Observe the applicable national and international laws, standards and directives.

1.2.7 Risk of burns, scalds and frostbite due to hot and cold components

There is a risk of burns and frostbite from some components, particularly uninsulated pipelines.

- ▶ Only carry out work on the components once these have reached environmental temperature.

1.3 Regulations (directives, laws, standards)

- ▶ Observe the national regulations, standards, directives, ordinances and laws.



2 Notes on the documentation

2.1 Documents

- ▶ Always observe all the operating and installation instructions included with the system components.
- ▶ Pass these instructions and all other applicable documents on to the end user.

2.2 Validity of the instructions

These instructions apply only to:

Product
VWL 35/6 A 230V S2
VWL 55/6 A 230V S2
VWL 75/6 A 230V S2

2.3 Further information

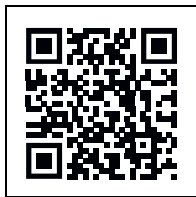

- ▶ Scan the displayed code using your smartphone in order to view further information about the installation.
 - ◀ You are guided to installation videos.

3 Product description

3.1 Heat pump system

Design of a typical heat pump system with monoblock technology:

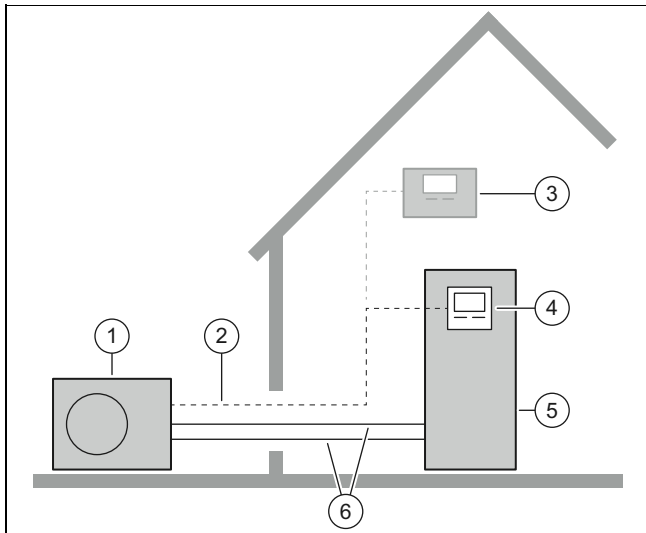

- | | |
|-------------------------------|--|
| 1 Outdoor unit | 5 Indoor unit with domestic hot water cylinder |
| 2 eBUS line | 6 Heating circuit |
| 3 Optional system control | |
| 4 Control for the indoor unit | |

3.2 Description of the product

The product is the outdoor unit of an air-to-water heat pump with monoblock technology.

3.3 Cooling mode

Depending on the country, the product has the heating mode or heating and cooling mode function.

Products that are delivered at the factory with no cooling mode are labelled with "S2" in the nomenclature. For these units, an optional accessory can be used to subsequently activate the cooling mode.

It is activated and operated via the indoor unit's control and the optional system control.

3.4 Noise reduction mode

The product has a noise reduction mode function.

In noise reduction mode, the product operates more quietly than in normal operating mode. This is achieved using a limited compressor rotational speed and an adjusted fan speed.

It is activated and operated via the indoor unit's control and the optional system control.

3.5 Functions of the heat pump

The heat pump has a closed refrigerant circuit in which refrigerant circulates.

In heating mode, cyclic evaporation, compression, liquefaction and expansion take in heat energy from the surroundings and transfer it to the building. In cooling mode, heat energy is extracted from the building and released into the environment.

3.5.1 Operating principle in heating mode

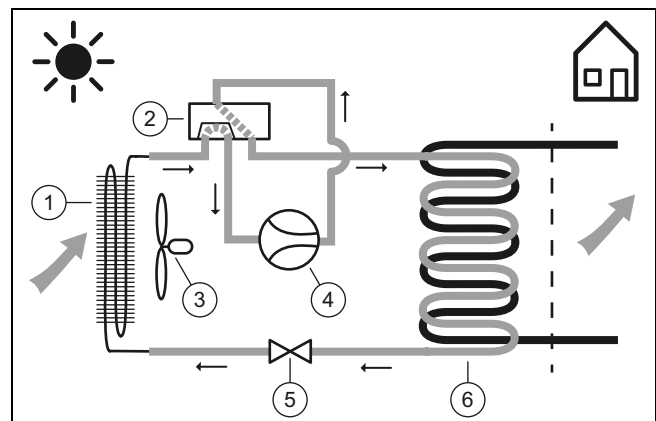

- | | |
|-------------------------|-------------------|
| 1 Evaporator | 4 Compressor |
| 2 4-port diverter valve | 5 Expansion valve |
| 3 Fan | 6 Condenser |

3.5.2 Operating principle in cooling mode

Validity: Product with cooling mode

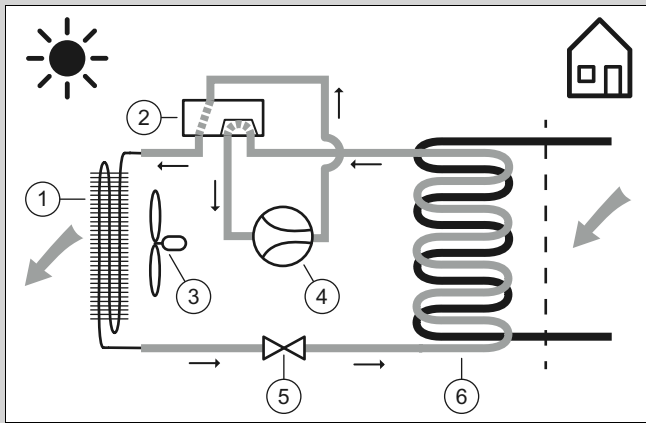

- | | | | |
|---|-----------------------|---|-----------------|
| 1 | Condenser | 4 | Compressor |
| 2 | 4-port diverter valve | 5 | Expansion valve |
| 3 | Fan | 6 | Evaporator |

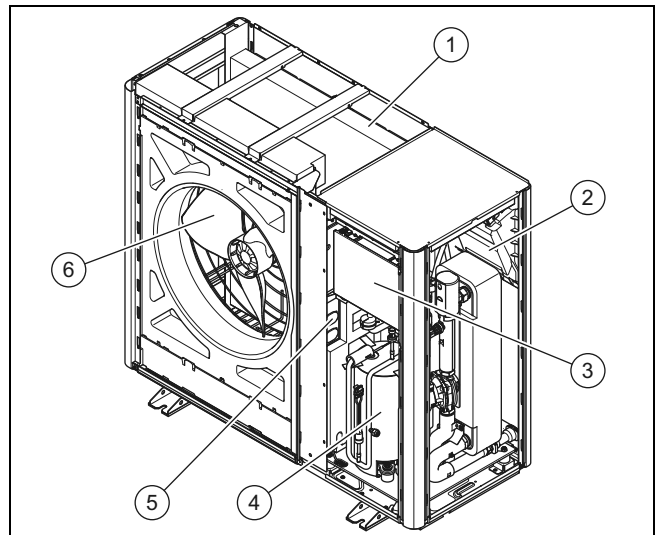

- | | | | |
|---|---------------------|---|-------------------|
| 1 | Evaporator | 4 | Compressor |
| 2 | INSTALLER BOARD PCB | 5 | INVERTER assembly |
| 3 | HMU PCB | 6 | Fan |

3.6 Product design

3.6.1 Unit

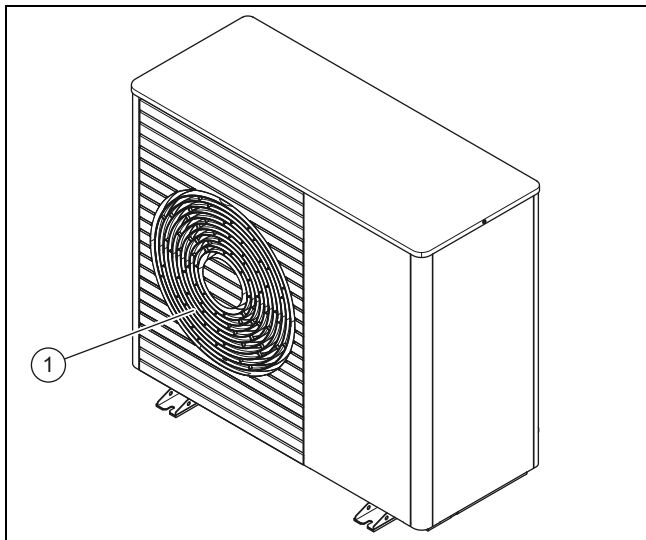

- | | |
|---|-------------------|
| 1 | Air outlet grille |
|---|-------------------|

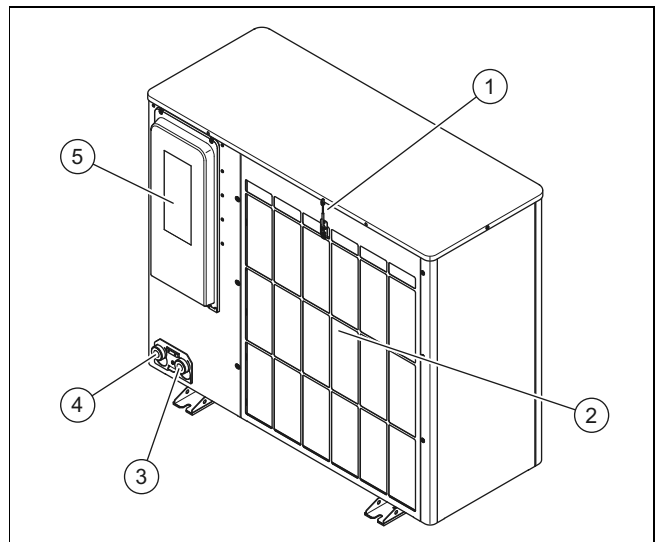

- | | | | |
|---|---------------------------------------|---|---|
| 1 | Temperature sensor at the air inlet | 4 | Connection for heating return, G 1 1/4" |
| 2 | Air inlet grille | 5 | Cover for the electrical connections |
| 3 | Connection for heating flow, G 1 1/4" | | |

3.6.2 Compressor assembly, front view

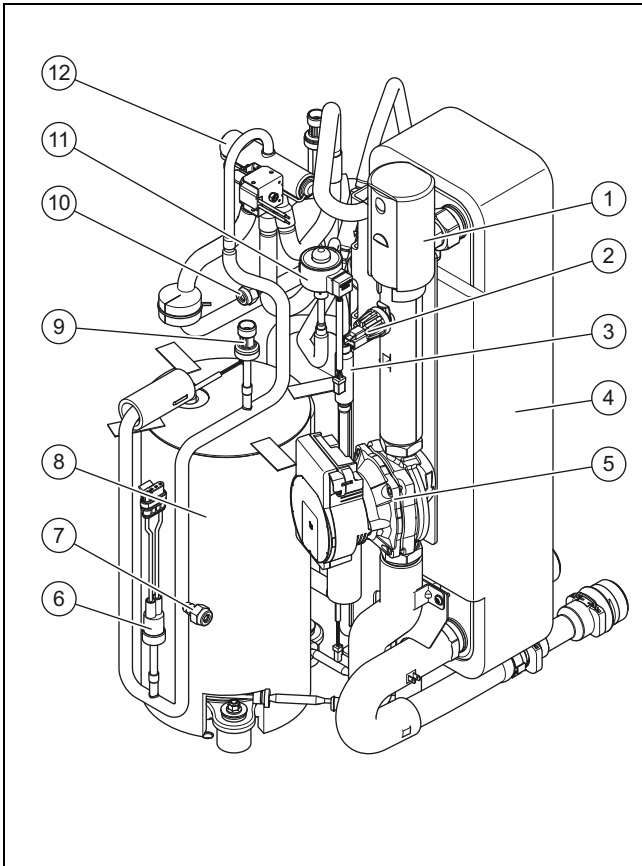

- | | | | |
|---|---|----|--|
| 1 | Automatic air vent | 7 | Maintenance connection in the high-pressure area |
| 2 | Pressure sensor in the heating circuit | 8 | Compressor |
| 3 | Filter | 9 | Pressure sensor in the high-pressure area |
| 4 | Condenser | 10 | Maintenance connection in the low-pressure area |
| 5 | Heating pump | 11 | Electronic expansion valve |
| 6 | Pressure switch in the high-pressure area | 12 | 4-port diverter valve |

3.6.3 Compressor assembly, rear view

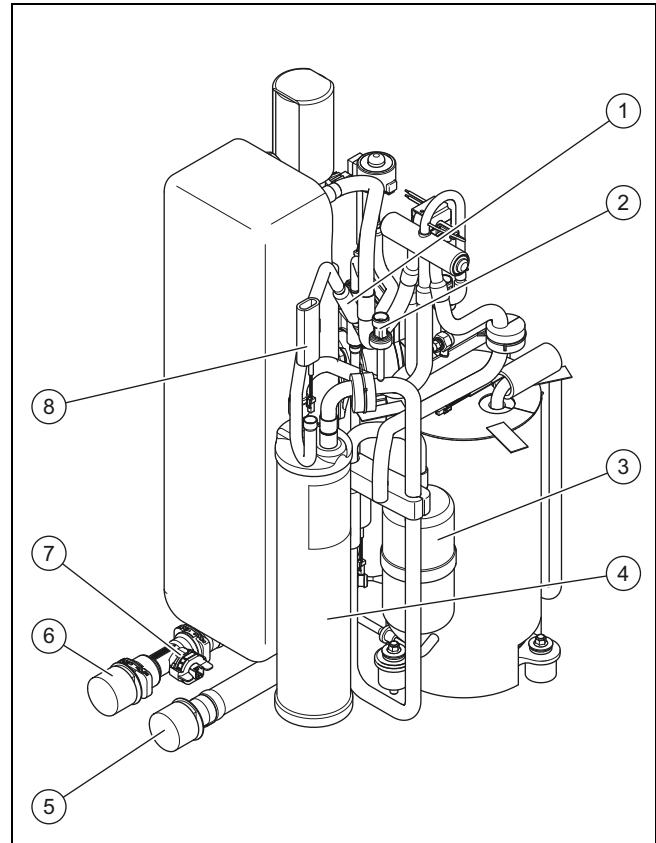





- | | | | |
|---|--|---|--------------------------------------|
| 1 | Filter | 5 | Connection for heating flow |
| 2 | Pressure sensor in the low-pressure area | 6 | Connection for heating return |
| 3 | Refrigerant separator | 7 | Flow rate sensor |
| 4 | Refrigerant buffer | 8 | Temperature sensor at the evaporator |

3.7 Information on the data plate



The data plate is located on the right-hand side of the product's exterior.

A second data plate is located inside the product. It becomes visible when the top casing is removed.

Information	Meaning
Serial no.	Unique unit identification number
VWL ...	Nomenclature
IP	Protection class
	Compressor
	Control
P max	Rated power, maximum
I max	Rated current, maximum
I	In-rush current
MPa (bar)	Permissible operating pressure
	Refrigerant circuit
R290	Refrigerant type
GWP	Global Warming Potential
kg	Fill quantity



Information	Meaning
t CO ₂	CO ₂ equivalent
Ax/Wxx	Air inlet temperature x °C and heating flow temperature xx °C
COP / 	Coefficient of performance/heating mode
EER / 	Energy efficiency ratio/cooling mode

3.8 Connection symbols

Symbol	Connection
	Heating flow, from the outdoor unit to the indoor unit
	Heating return, from the indoor unit to the outdoor unit

3.9 Warning sticker

Safety-relevant stickers are affixed to several points on the product. The warning stickers include rules of conduct for the R290 refrigerant. The warning stickers must not be removed.

Symbol	Meaning
	Warning against flammable materials in conjunction with R290 refrigerant.
	Fire, naked flames and smoke are prohibited.
	Read the service information and technical instructions.

3.10 CE marking



The CE marking shows that the products comply with the basic requirements of the applicable directives as stated on the declaration of conformity.

The declaration of conformity can be viewed at the manufacturer's site.

3.11 Benchmark

Vaillant is a licensed member of the Benchmark Scheme.

Benchmark places responsibilities on both manufacturers and installers. The purpose is to ensure that customers are provided with the correct equipment for their needs, that it is installed, commissioned and serviced in accordance with the manufacturer's instructions by a competent person approved at the time by the Health and Safety Executive and that it meets the requirements of the appropriate Building Regulations. The Benchmark Checklist can be used to demonstrate compliance with Building Regulations and should be provided to the customer for future reference.

Installers are required to carry out installation, commissioning and servicing work in accordance with the Benchmark Code of Practice which is available from the Heating and Hotwater Industry Council who manage and promote the Scheme.

Benchmark is managed and promoted by the Heating and Hotwater Industry Council.



For more information visit www.centralheating.co.uk

3.12 Application limits

The product works between a minimum and maximum outdoor temperature. These outdoor temperatures define the application limits for the heating mode, domestic hot water generation and cooling mode. Operating outside of the application limits leads to the product switching off.

3.12.1 Application limits, heating mode

In heating mode, the product works at outdoor temperatures of -25 °C to 43 °C.

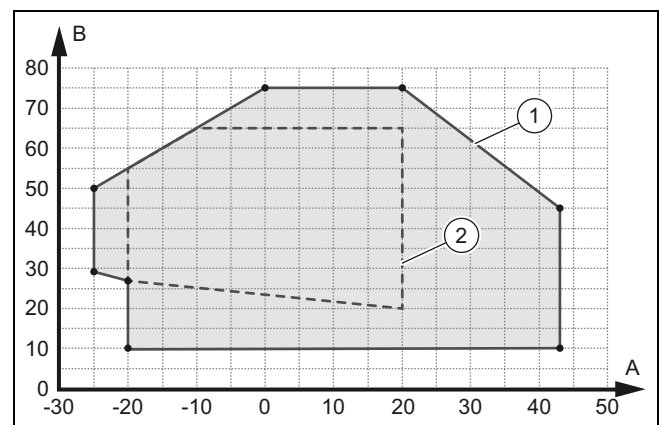

A	Outdoor temperature	1	Application limits, heating mode
B	Heating water temperature	2	Area of application, in accordance with EN 14511

3.12.2 Application limits, domestic hot water generation

For domestic hot water generation, the product works at outdoor temperatures of -20 °C to 43 °C.

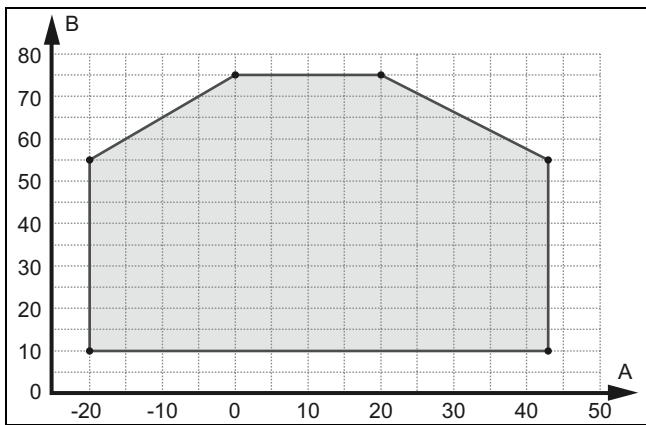

A Outdoor temperature B Heating water temperature

3.12.3 Application limits, cooling mode

Validity: Product with cooling mode

In cooling mode, the product works at outdoor temperatures of 15 °C to 46 °C.

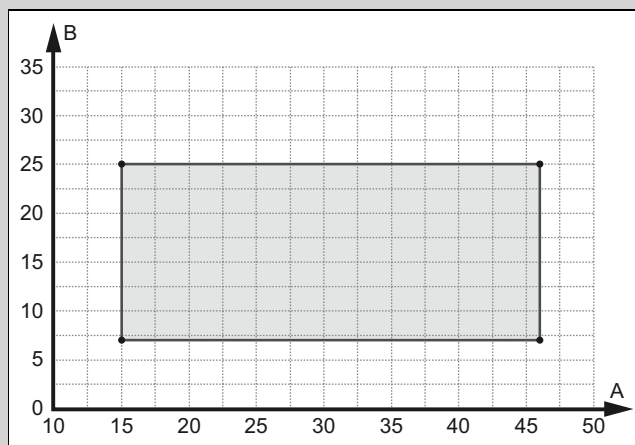

A Outdoor temperature B Heating water temperature

3.13 Thawing mode

At outdoor temperatures below 5 °C, condensation on the fins of the evaporator may freeze and frost may form. This frost is automatically detected and is automatically thawed at certain intervals.

The thawing occurs by reversing the refrigeration circuit while the heat pump is operating. The heat energy that is required for this is taken from the heating installation.

Correct thawing operation is only possible if the minimum volume of heating water is circulating in the heating installation:

Product	Activated back-up heater, heating water temperature > 25 °C	Deactivated back-up heater, heating water temperature > 15 °C
VWL 35/6 and VWL 55/6	15 litres	40 litres
VWL 75/6	20 litres	55 litres

3.14 Safety devices

The product is equipped with technical safety devices. See "Safety devices" graphic in the appendix.

If the refrigerant circuit pressure exceeds the maximum pressure of 3.15 MPa (31.5 bar), the pressure switch temporarily switches the product off. Following a waiting period, another attempt is made to start it. After three failed start attempts in succession, a fault message is displayed on the indoor unit's control panel.

If the product is switched off, the crankcase housing heating is switched on when the compressor outlet temperature reaches 7 °C. This prevents possible damage caused by switching the product back on.

If the temperature measured at the compressor outlet is higher than the permissible temperature, the compressor is switched off. The permissible temperature depends on the evaporation and condensation temperature.

The pressure in the heating circuit is monitored using a pressure sensor. If the pressure falls below 0.5 bar, a fault shutdown occurs. If the pressure rises to above 0.7 bar, the fault is reset again.

The heating circuit's circulation water volume is monitored using a flow rate sensor. If no flow rate can be detected when there is a heat demand when the circulation pump is running, the compressor does not start up.

If the heating water temperature falls below 4 °C, the product's frost protection function is automatically activated as the heating pump is started.

4 Protective zone

4.1 Protective zone

The product contains R290 refrigerant. Note that this refrigerant has a higher density than air. In the event of a leak, escaping refrigerant may collect near the ground.

The refrigerant must not collect in any way that may lead to a dangerous, explosive, suffocating or toxic atmosphere. The refrigerant must not get inside the building via building openings. The refrigerant must not collect in grooves.

A protective zone is defined around the product. There must be no windows, doors, light shafts, cellar entrances, escape hatches, flat-roof windows or ventilation openings in the protective zone.

There must be no ignition sources, such as plug sockets, light switches, lamps, electrical switches or other permanent ignition sources, in the protective zone.

The protective zone must not extend to adjacent buildings or public traffic areas.

In the protective zone, you are not permitted to make any subsequent structural alterations which infringe the stated rules for the protective zone.

4.1.1 Protective zone for ground installation on the premises

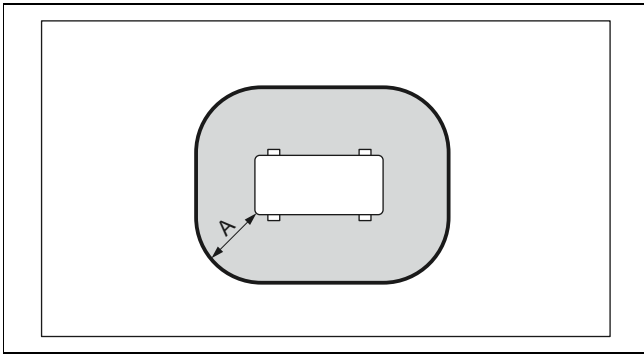

A 1000 mm

Dimension A is a clearance around the product.

4.1.2 Protective zone for ground installation in front of a building wall

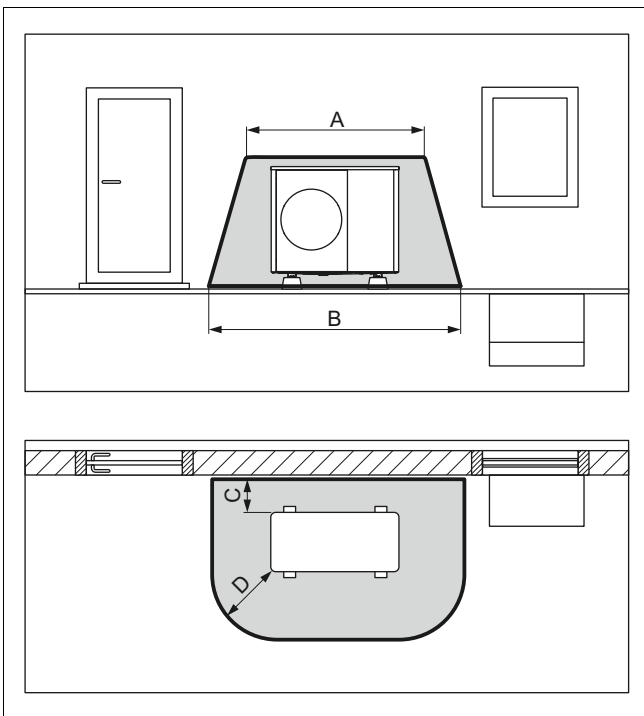

A 2100 mm C 200 mm/250 mm
B 3100 mm D 1000 mm

Dimension C is the minimum clearance that must be maintained to the wall (→ Section 5.4).

4.1.3 Protective zone for ground installation in a building corner

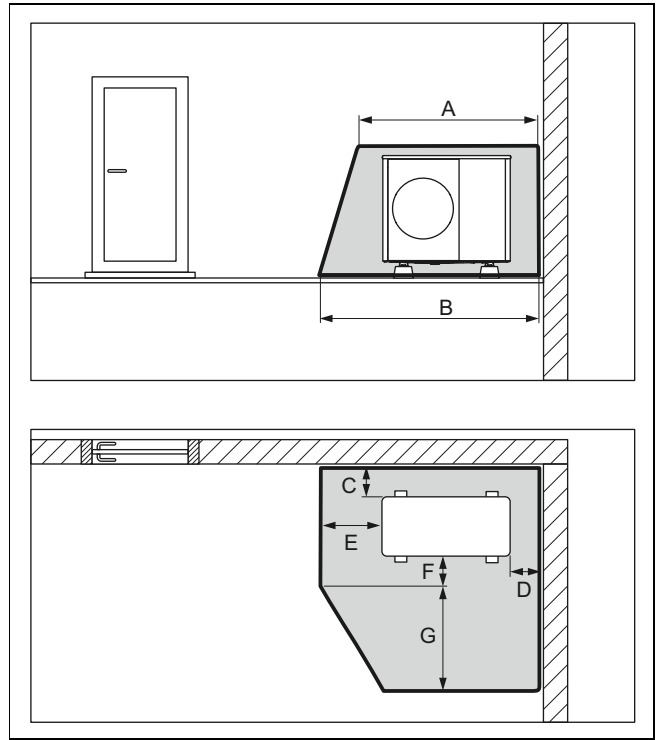

A 2100 mm E 1000 mm
B 2600 mm F 500 mm
C 200 mm/250 mm G 1800 mm
D 500 mm

The right-hand corner of the building is shown here. Dimensions C and D are the minimum clearances that must be maintained to the wall (→ Section 5.4). Dimension D varies for the left-hand corner of the building.

4.1.4 Protective zone for wall installation in front of a building wall

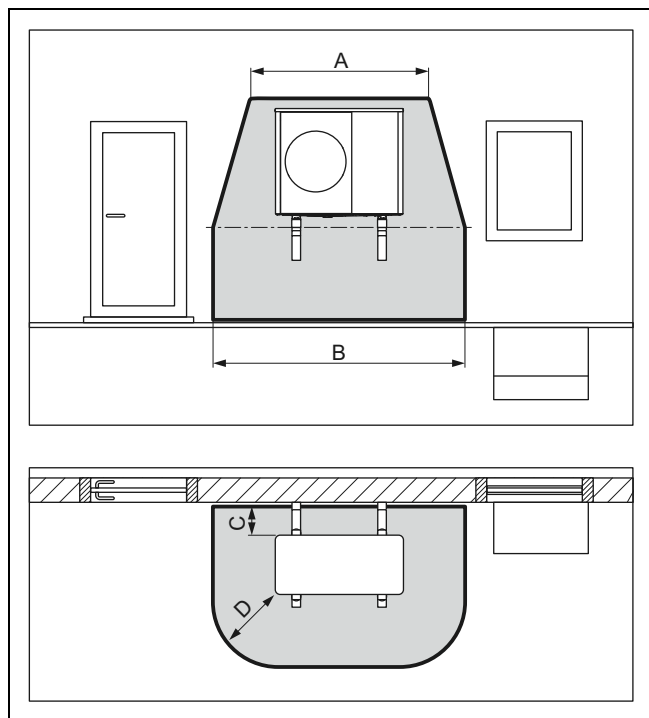

A	2100 mm	C	200 mm/250 mm
B	3100 mm	D	1000 mm

The protective zone below the product extends as far as the floor.

Dimension C is the minimum clearance that must be maintained to the wall (→ Section 5.4).

4.1.5 Protective zone for wall installation in a building corner

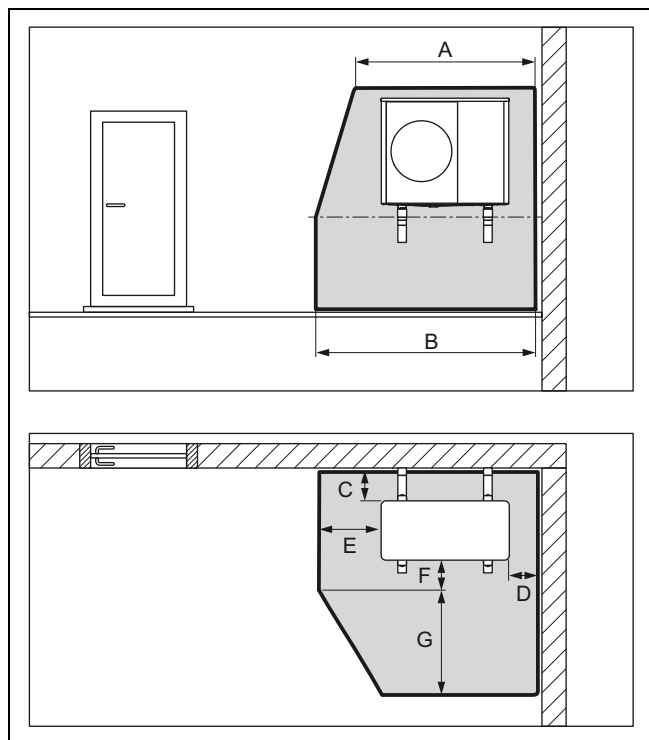

A	2100 mm	C	200 mm/250 mm
B	2600 mm	D	500 mm

E	1000 mm	G	1800 mm
F	500 mm		

The protective zone below the product extends as far as the floor.

The right-hand corner of the building is shown here. Dimension C is the minimum clearance that must be maintained to the wall (→ Section 5.4). Dimension D varies for the left-hand corner of the building.

4.1.6 Protective zone for flat-roof installation

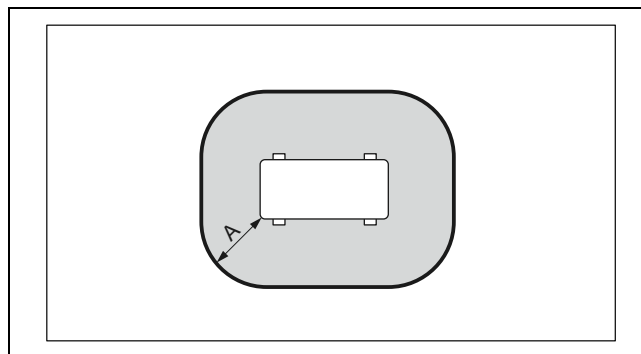

A	1000 mm
---	---------

Dimension A is a clearance around the product.

4.2 Design of the condensate discharge

The condensate that accumulates can be guided into a sewer, pump sump or soakaway via a downpipe, gully, balcony run-off or roof run-off. Open gullies or downpipes within the protective zone do not pose any safety risk.

For all installation types, you must ensure that any condensate that accumulates is discharged frost-free.

4.2.1 Design of the condensate discharge for ground installation

For the ground installation, the condensate must be discharged via a downpipe into a gravel bed which is located in the frost-free area.

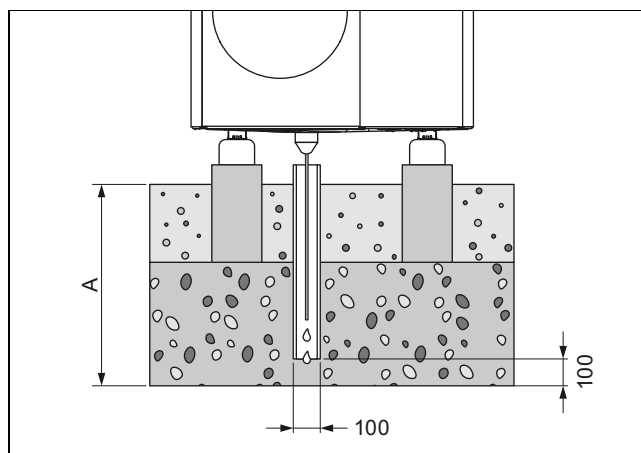

For a region with ground frost, dimension A is ≥ 900 mm and, for a region without ground frost, it is ≥ 600 mm.

The downpipe must flow into a sufficiently large gravel bed so that the condensate can trickle away freely.

To prevent the condensate from freezing, the heating wire must be threaded into the downpipe via the condensate discharge tundish.

4.2.2 Design of the condensate discharge for wall installation

For wall installation, the condensate can be discharged into a gravel bed that is located below the product.

Alternatively, the condensate can be discharged by connecting the condensate discharge pipe to a downpipe. In this case, depending on the local conditions, you must use electrical trace heating in order to keep the condensate discharge pipe frost-free.

4.2.3 Design of the condensate discharge for flat-roof installation

For flat-roof installation, the condensate can be discharged by connecting a condensate discharge pipe to a downpipe or a roof run-off. In this case, depending on the local conditions, you must use electrical trace heating in order to keep the condensate discharge pipe frost-free.

5 Set-up

5.1 Checking the scope of delivery

- ▶ Check the contents of the packaging units.

Quantity	Designation
1	Product
1	Condensate discharge tundish
1	Bag with small parts
1	Enclosed documentation

5.2 Transporting the product



Warning. Risk of injury from lifting a heavy weight.

Lifting weights that are too heavy may cause injury to the spine, for example.

- ▶ Note the weight of the product.
- ▶ Lift the product with four people.



Caution. Risk of material damage due to incorrect transportation.

The product must never be tilted at an angle of more than 45°. Otherwise, this may lead to faults in the refrigerant circuit during subsequent operation.

- ▶ During transport, do not tilt the product by any more than the maximum angle of 45°.

1. Take into consideration the weight distribution during transport. The product is significantly heavier on the right-hand side than on the left-hand side.
2. Undo the screwed connection between the product and the pallet.

3. Use the transport straps or a suitable hand truck.
4. Protect the casing sections against damage.
5. After transport, remove the transport straps.

5.3 Dimensions

5.3.1 Front view

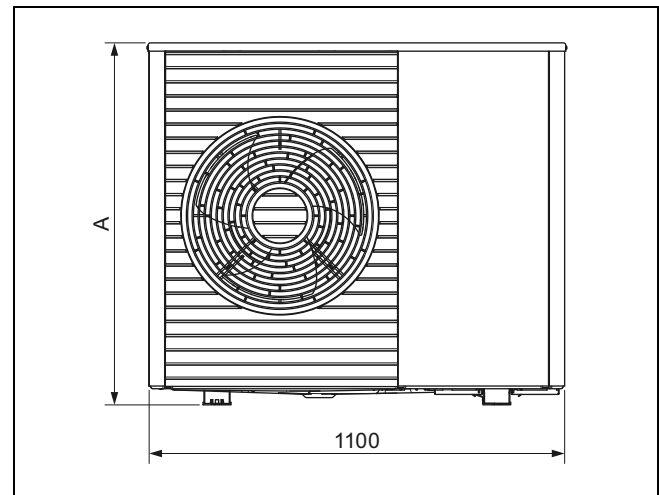

Product	A
VWL 35/6 ...	765
VWL 55/6 ...	765
VWL 75/6 ...	965

5.3.2 Side view, right

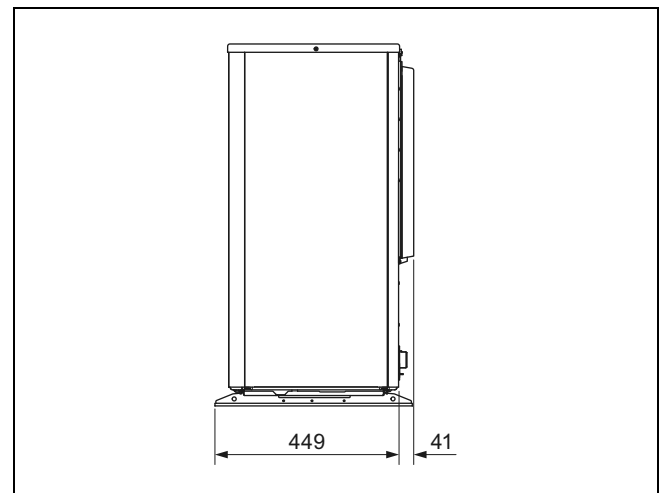

5.3.3 Bottom view

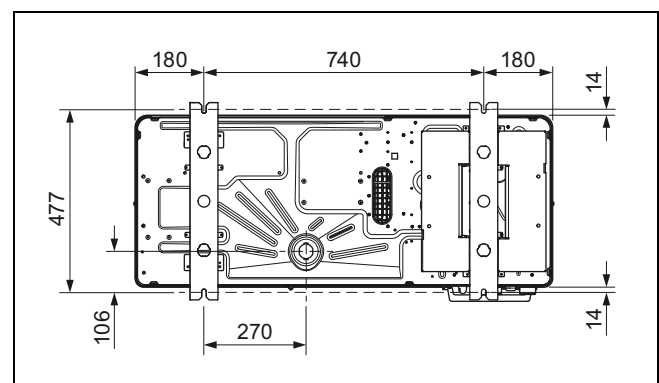

5.3.4 Rear view

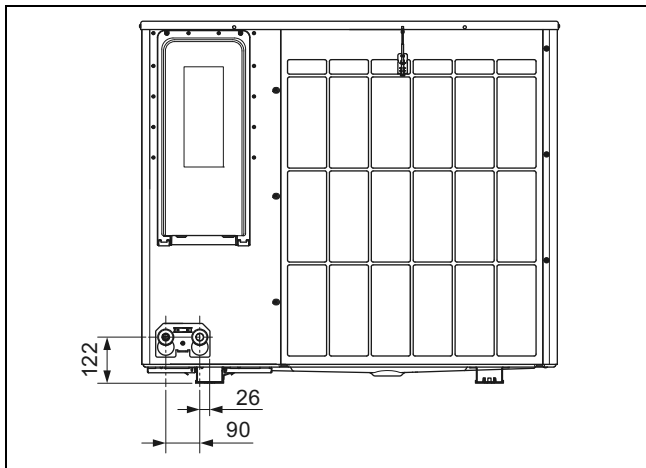

5.4 Complying with minimum clearances

- ▶ To guarantee sufficient air flow and to facilitate maintenance work, observe the minimum clearances that are specified.
- ▶ Ensure that there is sufficient room to install the hydraulic lines.

Validity: Floor installation OR Flat roof installation

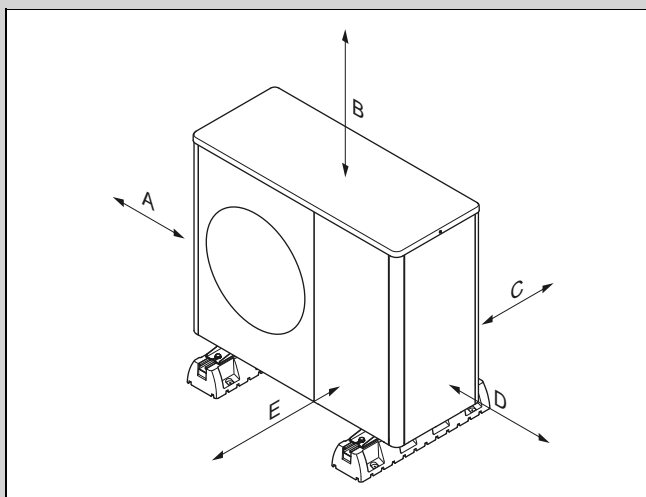

Minimum clearance	Heating mode	Heating and cooling mode
A	100 mm	100 mm
B	1000 mm	1000 mm
C	200 mm	250 mm
D	500 mm	500 mm
E	600 mm	600 mm

Validity: Wall-mounting

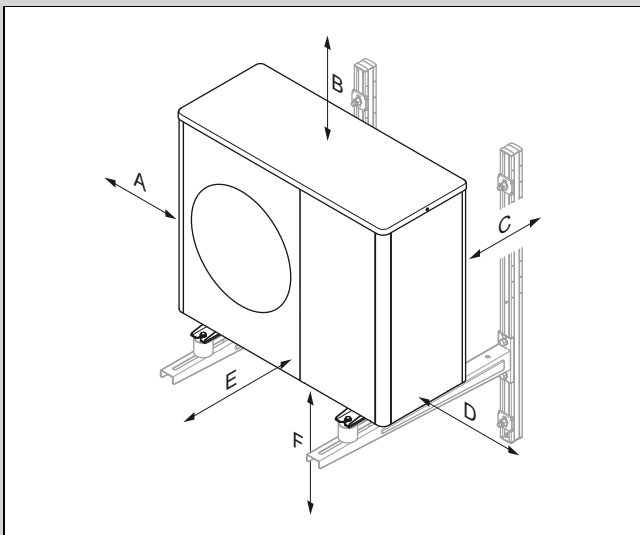

Minimum clearance	Heating mode	Heating and cooling mode
A	100 mm	100 mm
B	1000 mm	1000 mm
C	200 mm	250 mm
D	500 mm	500 mm
E	600 mm	600 mm
F	300 mm	300 mm

5.5 Conditions for the installation type

The product is suitable for the following installation types: Ground installation, wall installation and flat-roof installation.

The pitched-roof installation is not permitted.

5.6 Selecting the installation site



Danger! **Risk of injury due to ice formation.**

The air temperature at the air outlet is below the outdoor temperature. This can lead to ice formation.

- ▶ Select a site and an orientation at which the air outlet is at least 3 m away from walkways, plastered surfaces and down-pipes.

- ▶ Note that installation in sinks or areas that do not allow free outflow of air is not permitted.
- ▶ If the installation site is in the immediate vicinity of the coastline, ensure that the product is protected against spraying water by an additional protection device.
- ▶ Keep away from flammable substances or flammable gases.
- ▶ Keep away from heat sources.
- ▶ Do not expose the outdoor unit to dirty, dusty or corrosive air.
- ▶ Keep away from ventilation openings or ventilation ducts.
- ▶ Keep away from deciduous trees and shrubs.
- ▶ Please note that the installation site must be below 2000 m above sea level.

- ▶ Select an installation site that is as far away from your own bedroom as possible.
- ▶ Please note the noise emissions. Select an installation site that is as far away from the windows of adjacent building as possible.
- ▶ Select an installation site that is easily accessible so that maintenance and service work can be carried out.
- ▶ If the installation site is adjacent to a vehicle shunting area, protect the product using ram protection.

Validity: Floor installation

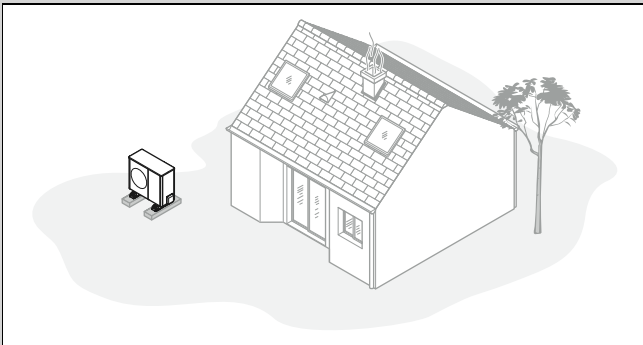

- ▶ Avoid choosing an installation site that is in the corner of a room, between walls or between fences.
- ▶ Prevent the return intake of air from the air outlet.
- ▶ Ensure that water cannot collect on the subsoil.
- ▶ Ensure that the subsoil can absorb water well.
- ▶ Plan a bed of gravel and rubble for the condensate discharge.
- ▶ Select an installation site which is free from significant accumulations of snow in winter.
- ▶ Select an installation site at which the air inlet is not affected by strong winds. Position the unit as crosswise to the main direction of wind as possible.
- ▶ If the installation site is not protected against the wind, you should plan to set up a protective wall.
- ▶ Please note the noise emissions. Avoid corners of rooms, recesses or sites between walls.
- ▶ Select an installation site with excellent sound absorption thanks to grass, hedges or fencing.
- ▶ Route the hydraulic lines and electrical wires underground.
- ▶ Provide a safety pipe that leads from the outdoor unit through the wall of the building.

Validity: Wall-mounting

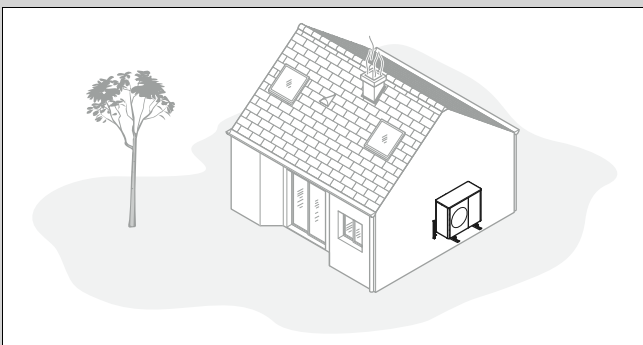

- ▶ Ensure that the structural design and load-bearing capacity of the wall complies with the requirements. Note the weight of the unit mounting bracket and the product.
- ▶ Avoid choosing an installation position which is near to a window.

- ▶ Please note the noise emissions. Maintain sufficient clearance from reflective building walls.
- ▶ Route the hydraulic lines and electrical wires.
- ▶ Provide a wall duct.

Validity: Flat roof installation

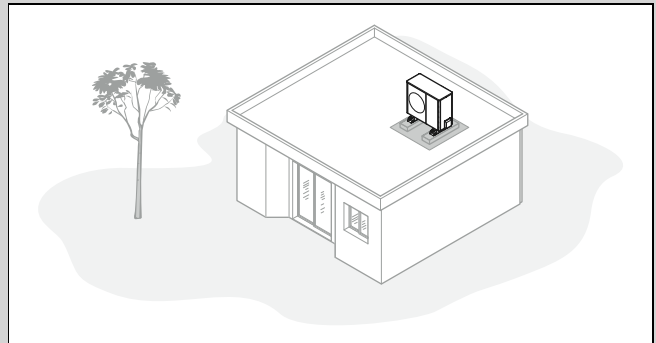

- ▶ Only install the product in buildings with a solid construction and that have cast concrete ceilings throughout.
- ▶ Do not install the product in buildings with a wooden structure or with a lightweight roof.
- ▶ Select an installation site that is easily accessible so that foliage or snow can be regularly removed from the product.
- ▶ Select an installation site at which the air inlet is not affected by strong winds. Position the unit as crosswise to the main direction of wind as possible.
- ▶ If the installation site is not protected against the wind, you should plan to set up a protective wall.
- ▶ Please note the noise emissions. Maintain sufficient clearance from adjacent buildings.
- ▶ Route the hydraulic lines and electrical wires.
- ▶ Provide a wall duct.

5.7 Preparing for fitting and installation



Danger!

Risk of death caused by fire or explosion if there is a leak in the refrigerant circuit!

The product contains the combustible refrigerant R290. In the event of a leak, escaping refrigerant may mix with air to form a flammable atmosphere. There is a risk of fire and explosion.

- ▶ Ensure that there are no ignition sources, such as plug sockets, light switches, lamps, electrical switches or other permanent ignition sources, in the protective zone.
-
- ▶ Observe the basic safety regulations before starting work.

5.8 Planning the foundation

Validity: Floor installation

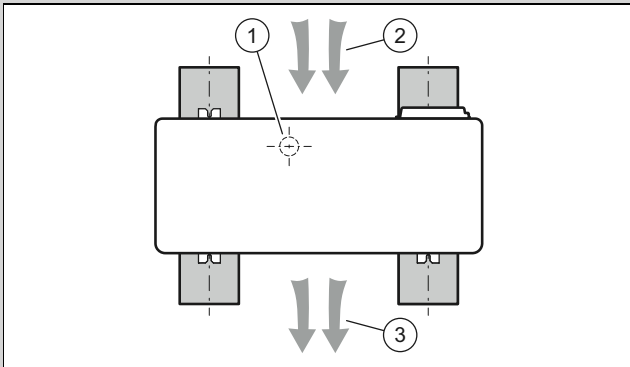

- ▶ Note the subsequent position and orientation of the unit on the strip foundations, as shown in the image.
- ▶ Ensure that the position (1) of the condensate discharge is not in the centre between the strip foundations.
- ▶ Ensure that the air inlet (2) is on the rear and the air outlet (3) is on the front of the unit.

5.9 Creating a foundation

Validity: Floor installation

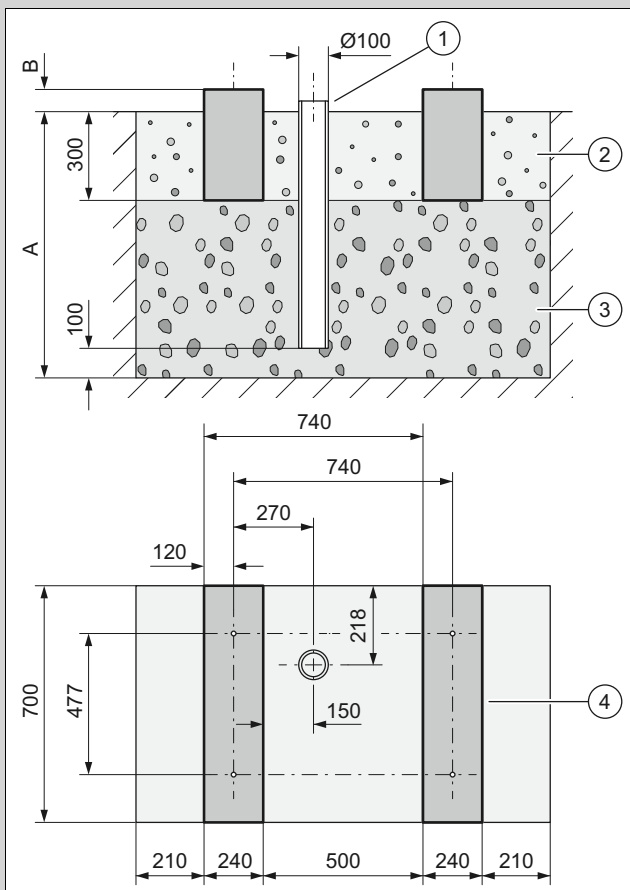

- ▶ Dig a hole in the ground. The recommended dimensions can be found in the figure.
- ▶ Insert a downpipe (1) to divert the condensate.
- ▶ Insert a layer of water-permeable coarse rubble (3).
- ▶ Calculate the depth (A) in accordance with local conditions.

- Region with ground frost: Minimum depth: 900 mm
- Region without ground frost: Minimum depth: 600 mm

- ▶ Calculate the height (B) in accordance with local conditions.
- ▶ Create two concrete strip foundations (4). The recommended dimensions can be found in the figure.
- ▶ Note that the clearances for the drill hole in the strip foundations only apply for the installation with the small damping feet.
- ▶ Add a gravel bed between and beside the strip foundations (2) to divert the condensate.

5.10 Guaranteeing occupational safety

Validity: Wall-mounting

- ▶ Ensure that the installation position on the wall can be safely accessed.
- ▶ If the work on the product takes place at a height above 3 m, install technical fall protection.
- ▶ Observe the local laws and regulations.

Validity: Flat roof installation

- ▶ Ensure that the flat roof can be safely accessed.
- ▶ Maintain a safety area of 2 m to the fall edge, plus the clearance that is required for working on the product. The safety area must not be entered.
- ▶ If this is not possible, then install technical fall protection at the fall edge, for example reliable railings. Alternatively, set up technical safety catch equipment, for example scaffolding or safety nets.
- ▶ Maintain sufficient clearance to any roof escape hatches and flat-roof windows. When carrying out the work, use suitable protective equipment (e.g. barriers) to prevent you from stepping on or falling through any escape hatches and flat-roof windows.

5.11 Installing the product

Validity: Floor installation

- ▶ Use the appropriate products from the accessories, depending on the required installation type.
 - Small damping feet
 - Large damping feet
 - Raised base and small damping feet
- ▶ Align the product horizontally.

Validity: Wall-mounting

- ▶ Check the design and load-bearing capacity of the wall. Note the weight of the product.
- ▶ Use the unit mounting bracket that is suitable for wall-mounting from the accessories.
- ▶ Use the small damping feet.
- ▶ Align the product horizontally.

Validity: Flat roof installation



Warning.

Risk of injury due to toppling over in the wind.

The product may topple over if there is a wind load.

- ▶ Use two concrete bases and an anti-slip protective mat.
- ▶ Screw the product to the concrete base.

- ▶ Use the large damping feet.
- ▶ Align the product horizontally.

5.12 Connecting the condensate discharge pipe



Danger!

Risk of injury due to frozen condensate.

Frozen condensate on paths may cause falls.

- ▶ Ensure that condensate does not discharge onto paths and that ice cannot build up there.

1. For all installation types, ensure that any condensate that accumulates is discharged frost-free.

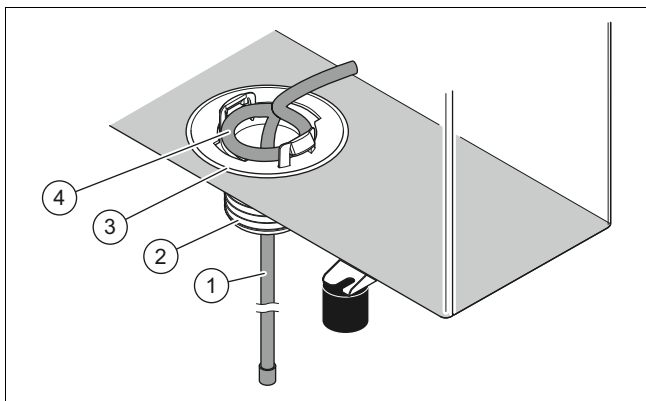

Validity: Floor installation

Condition: Version without drain pipework

- ▶ Install the supplied condensate discharge tundish (3).
- ▶ Slide the heating wire (1) from inside through the condensate discharge tundish and into the downpipe.
- ▶ Adjust the internal heating wire in such a way that the loop (4) lies concentric to the hole in the floor plate.

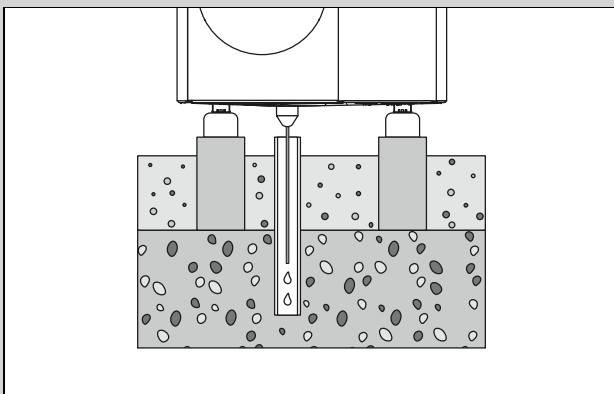

- ▶ Ensure that the condensate discharge tundish is positioned in the centre above the downpipe in the gravel bed.

Condition: Version with drain pipework

- ▶ Install this design only in regions without ground frost.
- ▶ Install the supplied condensate discharge tundish (3) and adapter (2).
- ▶ Connect the drain pipework to the adapter.
- ▶ Slide the heating wire (1) from inside through the condensate discharge tundish and the adapter and into the drain pipework.
- ▶ Adjust the internal heating wire in such a way that the loop (4) lies concentric to the hole in the floor plate.

Validity: Wall-mounting

Condition: Version without drain pipework

- ▶ Install the supplied condensate discharge tundish (3).
- ▶ Slide the heating wire (1) from inside through the condensate discharge tundish and to the outside.
- ▶ Slide the end of the heating wire from the outside through the condensate discharge tundish and back to the inside until it forms a U-shape within the condensate discharge tundish.
- ▶ Adjust the internal heating wire in such a way that the loop (4) lies concentric to the hole in the floor plate.
- ▶ Use the gravel bed below the product to drain away the condensate.

Condition: Version with drain pipework

- ▶ Install the supplied condensate discharge tundish (3) and adapter (2).
- ▶ Connect the drain pipework to the adapter and to a downpipe. In doing so, ensure that there is a sufficient downward gradient.
- ▶ Slide the heating wire (1) from inside through the condensate discharge tundish and the adapter and into the drain pipework.
- ▶ Adjust the internal heating wire in such a way that the loop (4) lies concentric to the hole in the floor plate.
- ▶ If the region is one with ground frost, install electrical trace heating for the drain pipework.

Validity: Flat roof installation

Condition: Version without drain pipework

- ▶ Install the supplied condensate discharge tundish (3).
- ▶ Slide the heating wire (1) from inside through the condensate discharge tundish and to the outside.
- ▶ Adjust the internal heating wire in such a way that the loop (4) lies concentric to the hole in the floor plate.
- ▶ Use the flat roof to drain away the condensate.

Condition: Version with drain pipework

- ▶ Install the supplied condensate discharge tundish (3) and adapter (2).
- ▶ Connect the drain pipework to the adapter and to a downpipe over a short distance. In doing so, ensure that there is a sufficient downward gradient.
- ▶ Slide the heating wire (1) from inside through the condensate discharge tundish and the adapter and into the drain pipework.
- ▶ Adjust the internal heating wire in such a way that the loop (4) lies concentric to the hole in the floor plate.
- ▶ If the region is one with ground frost, install electrical trace heating for the drain pipework.

5.13 Setting up a protective wall

Validity: Floor installation OR Flat roof installation

- ▶ If the installation site is not protected against the wind, set up a protective wall against the wall.
- ▶ Comply with the minimum clearances.

5.14 Removing/installing the casing sections

The following work must only be carried out when required or during maintenance work or repair work.

The following tool is required for this:

- Screwdriver for T20 tapping screw

5.14.1 Removing the top casing

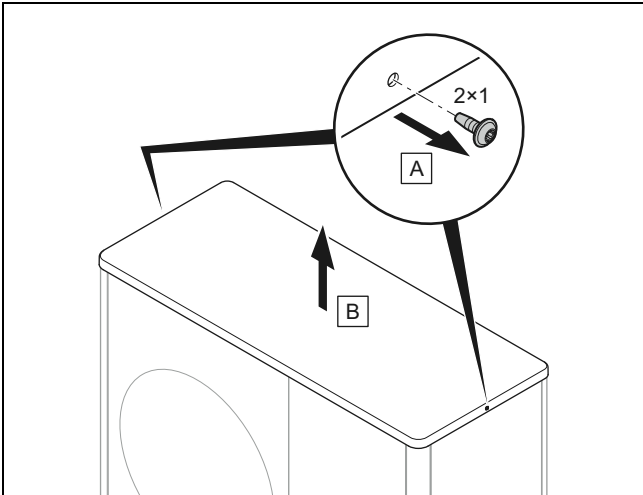

- ▶ Remove the top casing as shown in the figure.

5.14.2 Removing the right-hand side casing

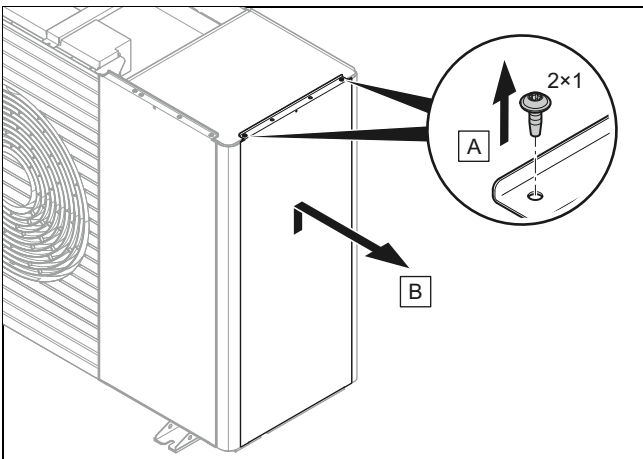

- ▶ Remove the right-hand side casing as shown in the figure.

5.14.3 Removing the front casing

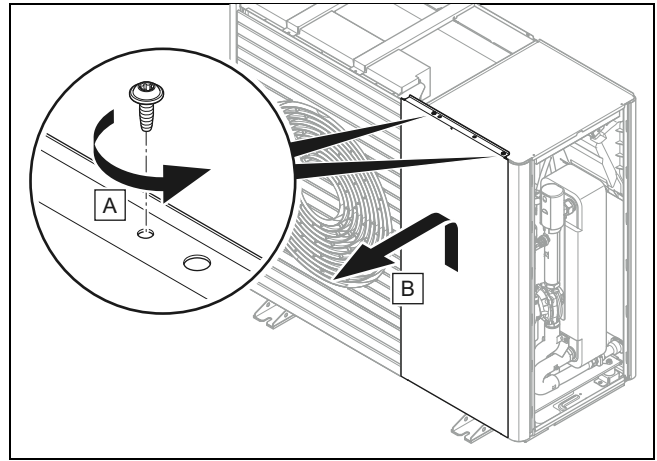

- ▶ Remove the front casing as shown in the illustration.

5.14.4 Removing the air outlet grille

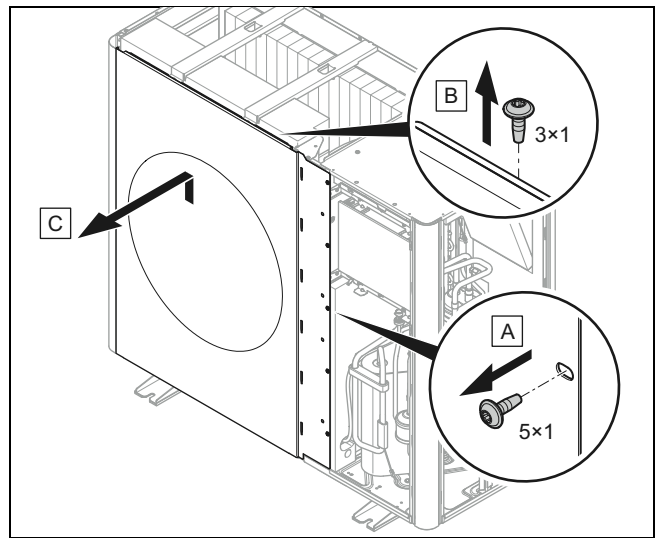

- ▶ Remove the air outlet grille as shown in the figure.

5.14.5 Removing the left-hand side casing

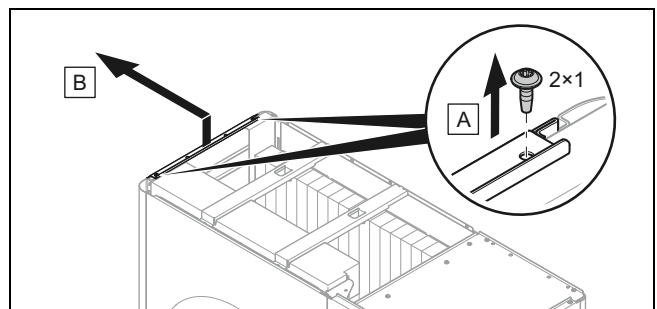

- ▶ Remove the left-hand side casing as shown in the figure.

5.14.6 Removing the air inlet grille

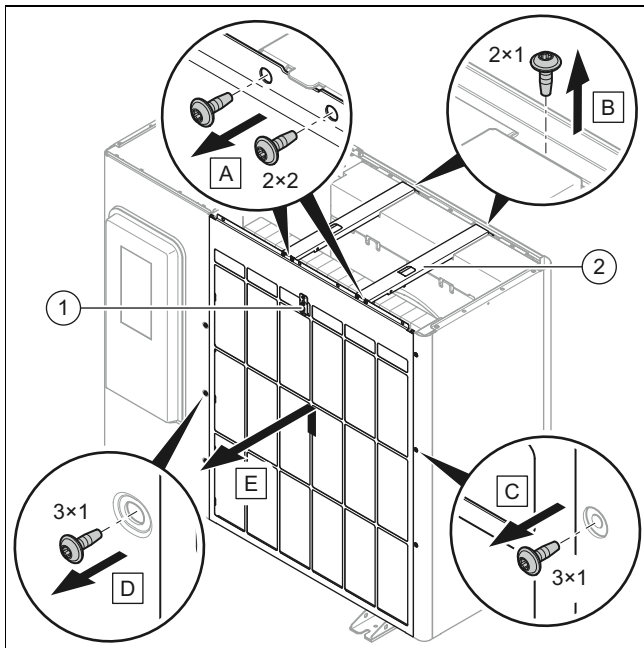

1. Disconnect the electrical connection to the temperature sensor (1).
2. Remove the two cross-members (2) as shown in the figure.
3. Remove the air inlet grille as shown in the figure.

5.14.7 Installing the casing sections

1. When installing, carry out the steps for removal in reverse.
2. To do this, follow the figures for the removal (→ Section 5.14.1).

6 Hydraulics installation

6.1 Installation type: Direct connection or system separation

In the case of a direct connection, the outdoor unit is hydraulically connected directly to the indoor unit and the heating installation. In this case, if there is frost, there is a risk that the outdoor unit will freeze.

In the case of a system separation, the heating circuit is separated into a primary and a secondary heating circuit. In this case, the separation is implemented using an optional intermediate heat exchanger, which is positioned in the indoor unit or in the building. If the primary heating circuit is filled with a water/frost protection mixture, the outdoor unit is protected against freezing in the case of frost or a power cut.

6.2 Guaranteeing the minimum circulation water volume

In heating installations that are equipped primarily with thermostatic or electrically controlled valves, a constant and sufficient flow through the heat pump must be ensured. When designing the heating installation, the minimum circulation water volume of heating water must be guaranteed.

6.3 Requirements for hydraulic components

Plastic pipes that are used for the heating circuit between the building and the product must be diffusion-tight.

Pipelines that are used for the heating circuit between the building and the product must have UV- and high-temperature-resistant thermal insulation.

6.4 Preparing the hydraulics installation

1. Flush the heating installation thoroughly before connecting the product in order to remove any possible residue from the pipelines.
2. If you carry out soldering work on connectors, carry this out while the associated pipelines have not yet been installed on the product.
3. Install a line strainer in the pipeline for the heating return.

6.5 Routing pipelines to the product

1. Route the pipelines for the heating circuit from the building, through the wall duct and to the product.

Validity: Floor installation

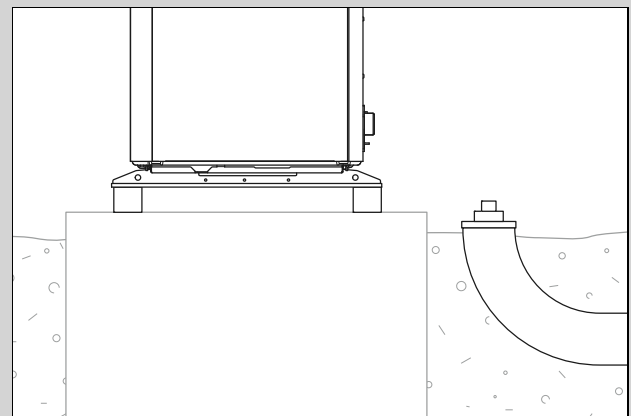

- ▶ Route the pipelines through a suitable safety pipe in the ground, as shown in the example in the figure.
- ▶ You can find the dimensions and clearances in the set-up instructions for the accessories (pre-installation jig, installation set).

Validity: Wall-mounting

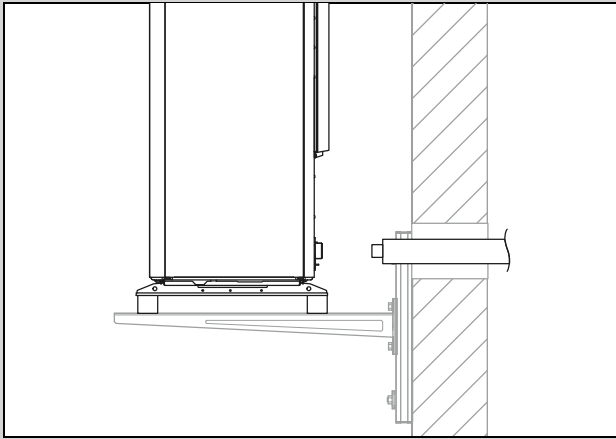

- ▶ Route the pipelines through the wall duct to the product, as shown in the figure.
- ▶ Route the pipelines from the inside outwards with a downward gradient of approx. 2°.
- ▶ You can find the dimensions and clearances in the set-up instructions for the accessories (pre-installation jig, installation set).

6.6 Connecting the pipelines to the product

1. Remove the covering caps from the hydraulic connections.

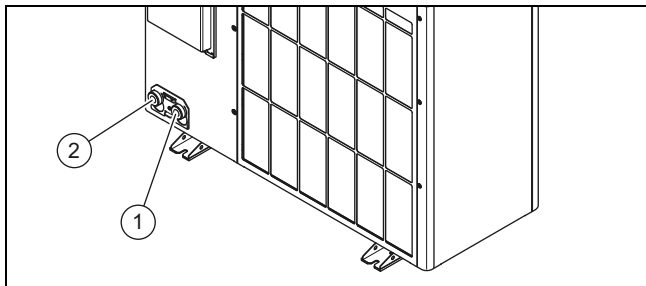

- 1 Heating flow, G 1 1/4" 2 Heating return, G 1 1/4"

2. Connect the pipelines for the heating circuit.

Validity: Floor installation

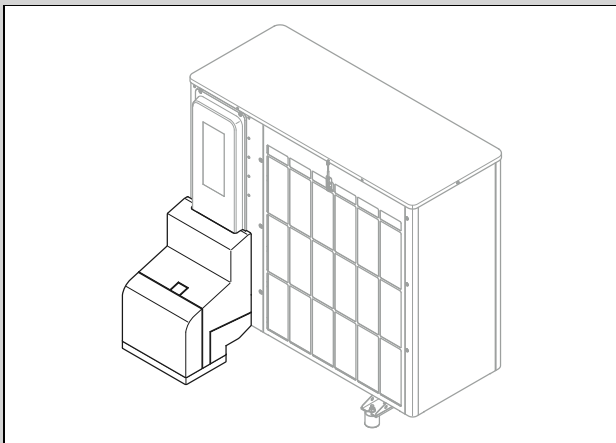

- ▶ Use the pre-installation jig and the enclosed components from the accessories.
- ▶ Check all connections for tightness.

Validity: Wall-mounting

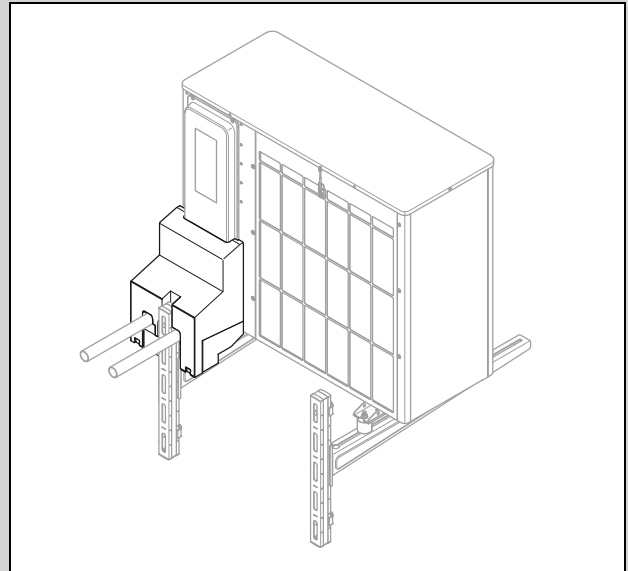

- ▶ Use the pre-installation jig and the enclosed components from the accessories.
- ▶ Check all connections for tightness.

6.7 Completing the hydraulics installation

1. Depending on the installation configuration, install additional required safety-relevant components.
2. When the product is not installed at the highest point in the heating circuit, install additional purging valves in elevated places where air may collect.
3. Check all connections for tightness.

6.8 Option: Connecting the product to a swimming pool

1. Do not connect the product's heating circuit directly to a swimming pool.
2. Use a separation heat exchanger that is suitable and the additional components that are required for this installation.

7 Electrical installation

This unit complies with IEC 61000-3-12 under the prerequisite that the short circuit line S_{sc} at the connection point for the customer's installation to the public grid is greater than or equal to 33. It is the responsibility of the installer or end user of the unit to ensure, if necessary after consultation with the network operator, that this unit is only connected to one connection point with an S_{sc} value that is greater than or equal to 33.

7.1 Preparing the electrical installation



Danger!

Risk of death from electric shock as a result of an improper electrical connection!

An improper electrical connection may negatively affect the operational safety of the product and result in material damage or personal injury.

- ▶ Only carry out the electrical installation if you are a trained competent person and are qualified for this work.

1. Observe the technical connection conditions for connecting to the energy supply company's low-voltage network.
2. Determine whether the energy supply company lockout function has been provided for the product, and how the power supply for the product should be designed, depending on the type of shutdown.
3. Use the data plate to determine the product's rated current. Derive the suitable cable cross-sections for the electrical wires from this.
4. Prepare the routing of the electrical wires from the building and through the wall duct to the product. If the line length exceeds 10 m, prepare the separated routing of the power supply cable and sensor/bus line.

7.2 Requirements for the quality of the mains voltage

For the mains voltage of the single-phase 230 V network, a tolerance of +10% to -15% must be provided.

7.3 Requirements for electrical components

Flexible hose lines that are suitable for routing outdoors must be used for the power supply. The specification must comply with the standard 60245 IEC 57 with the abbreviation H05RN-F as a minimum.

The electrical partitions must have a contact gap of at least 3 mm.

For the electrical fuse protection, slow-blow fuses with C characteristics must be used.

To protect people, type B universal-current-sensitive residual-current circuit breakers must be used if these are stipulated for the installation site.

7.4 Requirements for the eBUS line

Observe the following rules when routing the eBUS lines:

- ▶ Use twin-core cables.
- ▶ Never use shielded or twisted cables.
- ▶ Use only appropriate cables, e.g. NYM or H05VV (-F/-U).
- ▶ Observe the permissible total length of 125 m. For a total length of up to 50 m, a conductor cross-section of $\geq 0.75 \text{ mm}^2$ applies; from 50 m upwards, a conductor cross-section of 1.5 mm^2 applies.

In order to prevent faults in the eBUS signals (e.g. due to interferences):

- ▶ Maintain a minimum clearance of 120 mm to power supply cables or other electromagnetic sources of interference.

- ▶ For parallel routing to mains connection lines, guide the cables in accordance with the applicable regulations, e.g. on cable trays.
- ▶ **Exceptions:** For wall breaks and in the electronics box, it is acceptable to not reach the minimum clearance.

7.5 Electrical partition

The electrical partition is also referred to as a "disconnector" in these instructions. The fuse or the circuit breaker that is installed in the building's meter/fuse box is usually used as the disconnecter.

7.6 Installing components for the energy supply company lockout function

With the energy supply company lockout function, the heat generation from the heat pump can be switched off temporarily by the energy supply company. The unit can be shut down in two ways:

1. The signal for the shutdown is fed to connection S21 for the indoor unit.
 2. The signal for the shutdown is fed to a partition that is installed on-site in the meter/fuse box.
- ▶ If the energy supply company lockout function is provided, install and wire additional components in the building's meter/fuse box.
 - ▶ To do this, follow the wiring diagram in the appendix of the installation instructions for the indoor unit.

7.7 Removing the cover for the electrical connections

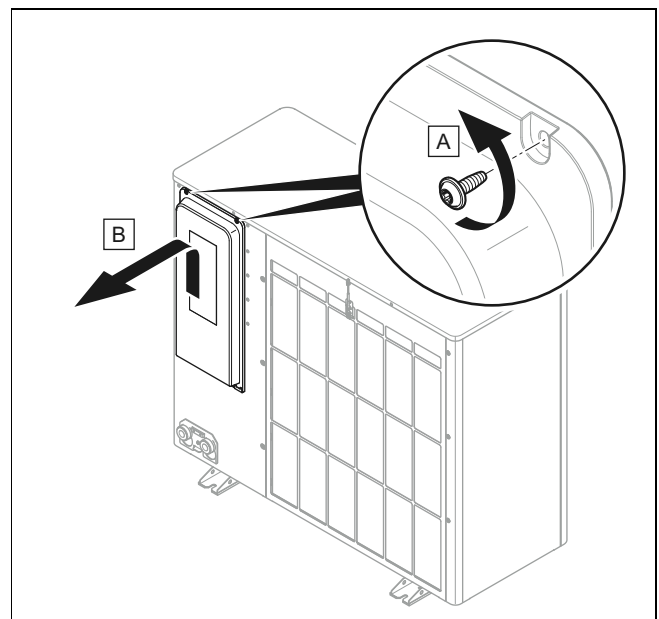

1. Note that the cover contains a safety-relevant seal which must be effective in the case of a leak in the refrigerant circuit.
2. Remove the cover, as shown in the figure, without damaging the circumferential seal.

7.8 Stripping the electrical wire

1. If required, shorten the electrical wire.

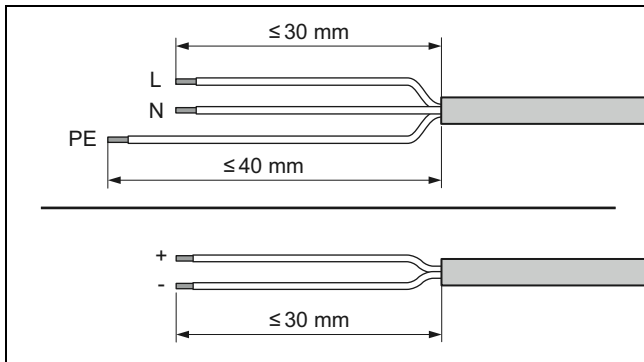

2. Strip the electrical wire as shown in the figure. In doing so, ensure that the insulation on the individual conductors is not damaged.
3. To avoid short circuits resulting from loose individual wires, fit conductor end sleeves on the stripped ends of the conductors.

7.9 Establishing the power supply, 1~/230V

- Determine the type of connection:

Case	Connection type
Energy supply company lockout not provided	Single power supply
Energy supply company lockout provided, shutdown via connection S21	
Energy supply company lockout provided, shutdown via partition	Dual power supply

7.9.1 1~/230V, single power supply

1. If it is stipulated for the installation site, install one residual-current circuit breaker for the product.

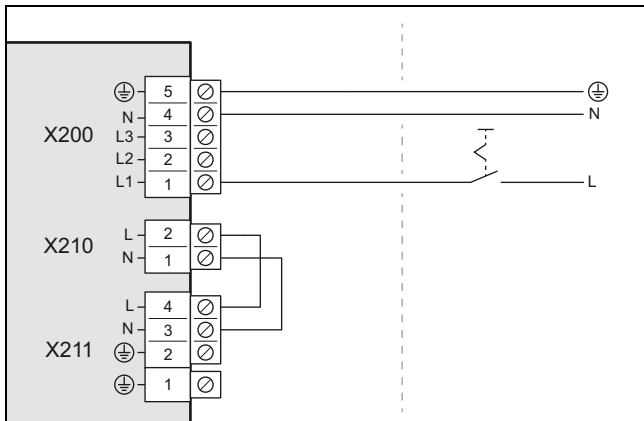

2. Install a disconnector for the product in the building, as shown in the figure.
3. Use one 3-pole power supply cable. Route this from the building and through the wall duct to the product.
4. Connect the power supply cable to connection X200 in the electronics box.
5. Use the strain relief clamp to secure the power supply cable in place.

7.9.2 1~/230V, dual power supply

1. If it is stipulated for the installation site, install two residual-current circuit breakers for the product.

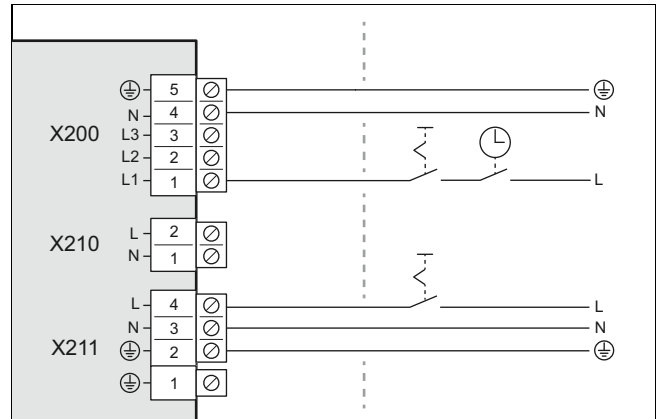

2. Install a partition for the product in the building, as shown in the figure.
3. Install two disconnectors for the product in the building, as shown in the figure.
4. Use two 3-pole power supply cables. Route this from the building and through the wall duct to the product.
5. Connect the power supply cable (from the heat pump electricity meter) to connection X200. This power supply may be temporarily switched off by the energy supply company.
6. Remove the 2-pole bridge from the X210 connection.
7. Connect the power supply cable (from the household electricity meter) to connection X211. This power supply is constant.
8. Use the strain relief clamps to secure the power supply cables in place.

7.10 Connecting the eBUS line

1. Use an eBUS line in accordance with the requirements (→ Section 7.4).
2. Route the eBUS line from the building and through the wall duct to the product.

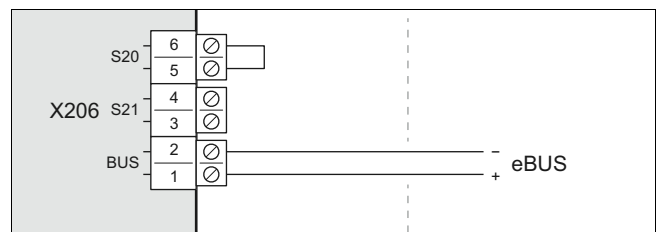

3. Connect the eBUS line to connection X206, BUS.
4. Use the strain relief clamp to secure the eBUS line in place.

7.11 Connecting a limit thermostat

Condition: No intermediate heat exchanger is installed in the indoor unit

- ▶ Use a 2-pole cable with a conductor cross-section of at least 0.75 mm².
- ▶ Route the cable from the building and through the wall duct to the product.

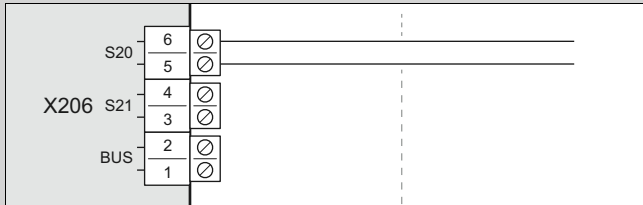

- ▶ Remove the bridge from the X206, S20 connection. Connect the cable here.
- ▶ Use the strain relief clamp to secure the cable in place.

Condition: Intermediate heat exchanger installed in the indoor unit

- ▶ Connect the limit thermostat to the indoor unit (→ Installation instructions about the indoor unit).

7.12 Connecting accessories

- ▶ Observe the wiring diagram in the appendix.

7.13 Installing the cover for the electrical connections

1. Note that the cover contains a safety-relevant seal which must be effective in the case of a leak in the refrigerant circuit.
2. Secure the cover by lowering it into the stop on the lower edge.
3. Use two screws to secure the cover to the upper edge.

8 Start-up

8.1 Checking before switching on

- ▶ Check whether all the hydraulic connections are established correctly.
- ▶ Check whether all the electrical connections are established correctly.
- ▶ Check, depending on the type of connection, whether one or two disconnectors are installed.
- ▶ If it is stipulated for the installation site, check whether a residual-current circuit breaker has been installed.
- ▶ Read through the operating instructions.
- ▶ After installation, ensure that at least 30 minutes have passed before switching on the product.
- ▶ Ensure that the cover for the electrical connections is installed.

8.2 Switching on the product

- ▶ Switch on all of the disconnectors to which the product is connected in the building.

8.3 Checking and treating the heating water/filling and supplementary water



Caution.

Risk of material damage due to poor-quality heating water

- ▶ Ensure that the heating water is of sufficient quality.

- ▶ Before filling or topping up the installation, check the quality of the heating water.

Checking the quality of the heating water

- ▶ Remove a little water from the heating circuit.
- ▶ Check the appearance of the heating water.
- ▶ If you ascertain that it contains sedimentary materials, you must desludge the installation.
- ▶ Use a magnetic rod to check whether it contains magnetite (iron oxide).
- ▶ If you ascertain that it contains magnetite, clean the installation and apply suitable corrosion-inhibition measures (e.g. fit a magnetite separator).
- ▶ Check the pH value of the removed water at 25 °C.
- ▶ If the value is below 8.2 or above 10.0, clean the installation and treat the heating water.
- ▶ Ensure that oxygen cannot get into the heating water.

Checking the filling and supplementary water

- ▶ Before filling the installation, measure the hardness of the filling and supplementary water.

Treating the filling and supplementary water

- ▶ Observe all applicable national regulations and technical rules when treating the filling and supplementary water.

Provided the national regulations and technical rules do not stipulate more stringent requirements, the following applies:

You must treat the heating water in the following cases

- If the entire filling and supplementary water quantity during the operating life of the system exceeds three times the nominal volume of the heating installation, or
- If the guideline values listed in the following table are not met, or
- If the pH value of the heating water is less than 8.2 or more than 10.0.

Total heating output	Water hardness at specific system volume ¹⁾					
	≤ 20 l/kW		> 20 l/kW ≤ 40 l/kW		> 40 l/kW	
kW	ppm CaCO ₃	mol/m ³	ppm CaCO ₃	mol/m ³	ppm CaCO ₃	mol/m ³
< 50	< 300	< 3	150	≤ 1.5	5	0.05
> 50 to ≤ 200	200	< 2	150	≤ 1.5	5	0.05
> 200 to ≤ 600	150	< 1.5	5	0.05	5	0.05
> 600	5	0.05	5	0.05	5	0.05

1) Nominal capacity in litres/heat output; in the case of multi-boiler systems, the smallest single heat output is to be used.



Caution.

Risk of material damage if the heating water is treated with unsuitable additives.

Unsuitable additives may cause changes in the components, noises in heating mode and possibly subsequent damage.

- ▶ Do not use any unsuitable antifreeze and corrosion inhibitors, biocides or sealants.

No incompatibility with our products has been detected to date with proper use of the following additives.

- ▶ When using additives, follow the manufacturer's instructions without exception.

We accept no liability for the compatibility of any additive or its effectiveness in the rest of the heating system.

Additives for cleaning measures (subsequent flushing required)

- Fernox F3
- Sentinel X 300
- Sentinel X 400

Additives intended to remain permanently in the installation

- Fernox F1
- Fernox F2
- Sentinel X 100
- Sentinel X 200

Additives for frost protection intended to remain permanently in the installation

- Fernox Antifreeze Alpha 11
- Sentinel X 500

- ▶ If you have used the above-mentioned additives, inform the end user about the measures that are required.
- ▶ Inform the end user about the measures required for frost protection.

8.4 Filling and purging the heating circuit

Validity: Direct connection

- ▶ Fill the product with heating water via the return. Slowly increase the filling pressure until the required operating pressure is reached.
 - Operating pressure: 0.15 to 0.2 MPa (1.5 to 2.0 bar)
- ▶ Activate the purge programme on the indoor unit's control.
- ▶ Check the system pressure during the purging process. If the pressure falls, top up the heating water until the required operating pressure is reached again.

Validity: System separation

- ▶ Fill the product and the primary heating circuit with a frost protection/water mixture (44% vol. propylene glycol and 56% vol. water) via the return. Slowly increase the filling pressure until the required operating pressure is reached.

- Operating pressure: 0.15 to 0.2 MPa (1.5 to 2.0 bar)

- ▶ Activate the purge programme on the indoor unit's control.
- ▶ Check the system pressure during the purging process. If the pressure falls, top up the frost protection/water mixture until the required operating pressure is reached again.
- ▶ Fill the secondary heating circuit with heating water. Slowly increase the filling pressure until the required operating pressure is reached.
 - Operating pressure: 0.15 to 0.2 MPa (1.5 to 2.0 bar)
- ▶ Activate the heating pump on the indoor unit's control.
- ▶ Check the system pressure during the purging process. If the pressure falls, top up the heating water until the required operating pressure is reached again.

8.5 Available remaining feed pressure

The following characteristics apply to the heating circuit for the outdoor unit and relate to a heating water temperature of 20 °C.

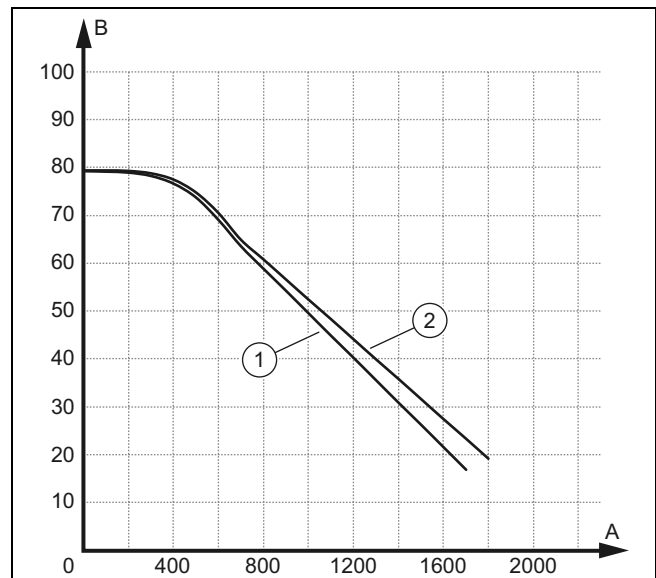

A	Volume flow, in l/h	1	VWL 35/6 and VWL 55/6
B	Remaining feed pressure, in kPa	2	VWL 75/6

9 Handing over to the end user

9.1 Instructing the end user

- ▶ Explain to the end user how the product operates. Inform them about whether a system separation is present and how the frost protection function is guaranteed.
- ▶ Point out, in particular, the safety warnings to the end user.
- ▶ Point out to the end user the particular risks and rules of conduct that are associated with R290 refrigerant.
- ▶ Make the end user aware of the need for regular maintenance.

10 Troubleshooting

10.1 Fault messages

In the event of a fault, a fault code is shown on the display of the indoor unit's control.

- ▶ Use the "Fault messages" table (→ installation instructions for the indoor unit, Appendix).

10.2 Other faults

- ▶ Use the "Troubleshooting" table (→ installation instructions for the indoor unit, Appendix).

11 Inspection and maintenance

11.1 Preparing for inspection and maintenance

- ▶ Only carry out the work if you are competent and have knowledge about the special features and risks of R290 refrigerant.



Danger!

Risk of death caused by fire or explosion if there is a leak in the refrigerant circuit!

The product contains the combustible refrigerant R290. In the event of a leak, escaping refrigerant may mix with air to form a flammable atmosphere. There is a risk of fire and explosion.

- ▶ If you are working on the product when it is open, before starting work, use a gas sniffer to ensure that there is no leak.
- ▶ In the case of a leak: Close the product's housing, inform the end user, and notify customer service.
- ▶ Keep all ignition sources away from the product. In particular, open flames, hot surfaces with temperatures above 370 °C, electrical devices that are not free from electrical sources, static discharges.
- ▶ Ensure that the room is sufficiently aerated around the product.
- ▶ Use a restriction to ensure that unauthorised personnel cannot enter the protective zone.

- ▶ Observe the basic safety rules before carrying out inspection and maintenance work or installing spare parts.
- ▶ When working in a raised position, observe the occupational safety rules (→ Section 5.10).
- ▶ Switch off all of the disconnectors to which the product is connected in the building.
- ▶ Disconnect the product from the power supply but ensure that the product is still earthed.
- ▶ When working on the product, protect all electric components from spraying water.

11.2 Observing the work plan and intervals

- ▶ Comply with the specified intervals. Carry out all of the work that is mentioned (Appendix D).

11.3 Procuring spare parts

The original components of the unit were also certified as part of the CE declaration of conformity. You can find information about available Vaillant original spare parts by contacting the contact address provided on the back page of these instructions.

- ▶ If you require spare parts for maintenance or repair work, use only Vaillant original spare parts.

11.4 Carrying out maintenance work

11.4.1 Checking the protective zone

- ▶ Check whether the defined protective zone is being maintained in the area close around the product. (→ Section 4.1)
- ▶ Check that no subsequent construction-related changes or installations that violate the protective zone have been implemented.

11.4.2 Cleaning the product

- ▶ Only clean the product when all of the casing sections and covers have been installed.
- ▶ Do not clean the product with a high-pressure cleaner or a direct jet of water.
- ▶ Clean the product using a sponge and hot water with cleaning agent.
- ▶ Do not use abrasive cleaners. Do not use solvents. Do not use any cleaning agents that contain chlorine or ammonia.

11.4.3 Removing the casing sections

1. Before removing the casing sections, use a gas sniffer to check whether refrigerant is escaping.
2. Remove the casing sections to the extent required for the subsequent maintenance work (→ Section 5.14.1).

11.4.4 Closing the purging valve

Condition: Only during the first service

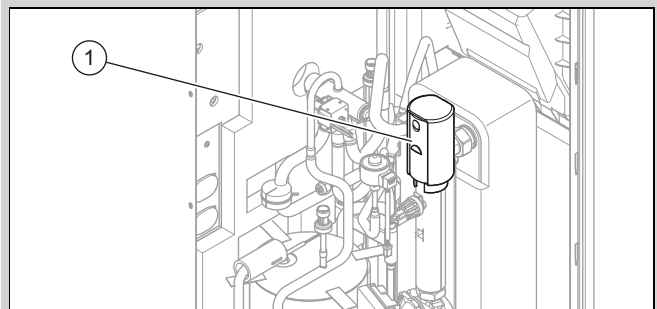

- ▶ Close the purging valve **(1)**.

11.4.5 Checking the evaporator, fan and condensate discharge

1. Clean the gaps between the fins using a soft brush. In doing so, avoid fins being bent.
2. Remove any dirt and depositions.
3. If required, straighten out any bent fins using a fin comb.
4. Turn the fan by hand.
5. Check that the fan runs freely.
6. Remove the dirt that has accumulated on the condensate tray or in the condensate discharge pipe.
7. Check that the water can drain freely. Pour approx. 1 l water into the condensate tray.
8. Ensure that the heating wire is inserted into the condensate discharge tundish.

11.4.6 Checking the refrigerant circuit

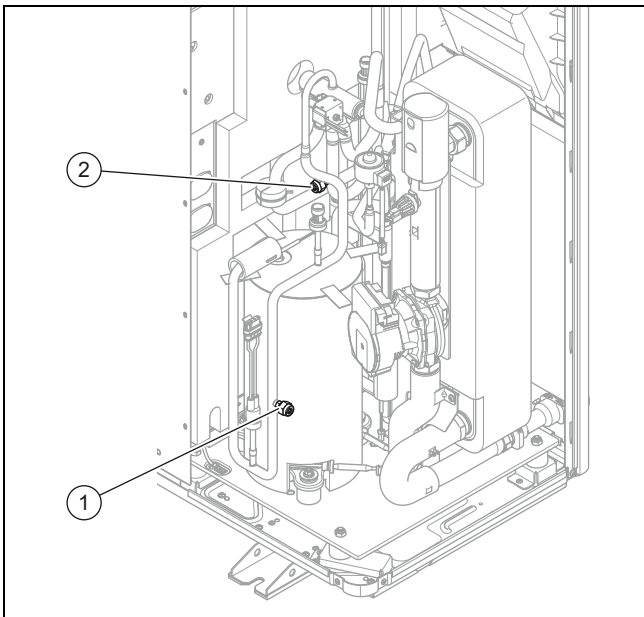

1. Check whether the components and pipelines are free from dirt and corrosion.
2. Check that the covering caps (1) and (2) on the maintenance connections are positioned securely.

11.4.7 Checking the refrigerant circuit for tightness

1. Check whether the components in the refrigerant circuit and the refrigerant pipes are free from damage, corrosion and oil leaks.
2. Check the refrigerant circuit for leak-tightness using a gas sniffer. In doing so, check all of the components and pipelines.
3. Document the result of the leak-tightness test in the service book.

11.4.8 Checking the electrical connections and electrical wires

1. On the connection box, check whether the seal is undamaged.
2. In the connection box, check that the electrical wires are seated firmly in the plugs or terminals.
3. Check the earthing in the connection box.
4. Check whether the power supply cable is damaged. If it needs to be replaced, ensure that it is only replaced

by Vaillant or customer service or a similarly qualified person in order to prevent hazards.

5. In the unit, check that the electrical wires are seated firmly in the plugs or terminals.
6. In the unit, check whether the electrical wires are free from damage.

11.4.9 Checking the small damping feet for wear

1. Check whether the damping feet are significantly compressed.
2. Check whether the damping feet have significant cracks.
3. Check whether there is substantial corrosion on the screwed connection for the damping feet.
4. If required, procure and install new damping feet.

11.5 Completing inspection and maintenance

- ▶ Installing the casing sections.
- ▶ Switch on the disconnector to which the product is connected in the building.
- ▶ Start up the product.
- ▶ Carry out an operational test and a safety test.

12 Repair and service

12.1 Preparing repair and service work on the refrigerant circuit

Only carry out work if you have specific expert refrigeration knowledge and are competent at handling R290 refrigerant.



Danger!

Risk of death caused by fire or explosion if there is a leak in the refrigerant circuit!

The product contains the combustible refrigerant R290. In the event of a leak, escaping refrigerant may mix with air to form a flammable atmosphere. There is a risk of fire and explosion.

- ▶ If you are working on the product when it is open, before starting work, use a gas sniffer to ensure that there is no leak.
- ▶ In the case of a leak: Close the product's housing, inform the end user, and notify customer service.
- ▶ Keep all ignition sources away from the product. In particular, open flames, hot surfaces with temperatures above 370 °C, electrical devices that are not free from electrical sources, static discharges.
- ▶ Ensure that the room is sufficiently aerated around the product.
- ▶ Use a restriction to ensure that unauthorised personnel cannot enter the protective zone.

- ▶ Switch off all of the disconnectors to which the product is connected in the building.
- ▶ Disconnect the product from the power supply but ensure that the product is still earthed.

- ▶ Restrict the working area and put up warning signs.
- ▶ Wear suitable personal protective equipment and bring a fire extinguisher with you.
- ▶ Use only safe units and tools that are permitted for R290 refrigerant.
- ▶ Monitor the atmosphere in the working area using a suitable gas detector that is positioned close to the floor.
- ▶ Remove all ignition sources, e.g. tools that are not spark-free. Take protective measures to prevent static discharges.
- ▶ Remove the top casing, the front casing and the right-hand side casing.

12.2 Removing refrigerant from the product



Danger!

Risk of death caused by fire or explosion when removing the refrigerant!

The product contains the combustible refrigerant R290. The refrigerant may mix with air to form a flammable atmosphere. There is a risk of fire and explosion.

- ▶ Only carry out the work if you are competent at handling R290 refrigerant.
- ▶ Wear suitable personal protective equipment and bring a fire extinguisher with you.
- ▶ Only use tools and units that are permitted for R290 refrigerant and are in proper working condition.
- ▶ Ensure that no air gets into the refrigerant circuit, into refrigerant-carrying tools or units, or into the refrigerant cylinder.
- ▶ Note that the refrigerant R290 must never be introduced into the sewage system.
- ▶ Do not use the compressor to pump the refrigerant into the outdoor unit (no pump-down).



Caution.

Risk of material damage when removing the refrigerant.

When removing the refrigerant, there is a risk of material damage caused by freezing.

- ▶ If no system separation is present, remove the heating water from the condenser (heat exchanger) before the refrigerant is removed from the product.

1. Procure the tools and units that are required for removing the refrigerant:
 - Extraction station
 - Vacuum pump
 - Recycling cylinder for refrigerant
 - Manometer bridge
2. Only use tools and units that are permitted for R290 refrigerant.
3. Use only recycling cylinders that are approved for R290 refrigerant, have been labelled appropriately, and are equipped with a pressure relief and isolation valve.

4. Only use hoses, couplings and valves that are leak-tight and in proper working condition. Check the tightness using a suitable gas sniffer.
5. Drain the recycling cylinder.
6. Extract the refrigerant. Take into account the maximum fill quantity of the recycling cylinder, and monitor the fill quantity using calibrated scales.
7. Ensure that no air gets into the refrigerant circuit, into refrigerant-carrying tools or units, or into the recycling cylinder.
8. Connect the manometer bridge to both the high-pressure side and the low-pressure sides of the refrigerant circuit and make sure that the expansion valve is open in order to ensure that the refrigerant circuit is completely drained.

12.3 Removing components of the refrigerant circuit

- ▶ Flush the refrigerant circuit with nitrogen.
- ▶ Drain the refrigerant circuit.
- ▶ Repeat the process of rinsing with nitrogen and draining until there is no longer any refrigerant in the refrigerant circuit.
- ▶ If you want to remove the compressor in which the compressor oil is located, use sufficient negative pressure to drain it for long enough to guarantee that there is no longer any combustible refrigerant in the compressor oil.
- ▶ Establish the atmospheric pressure.
- ▶ Use a pipe cutter to open the refrigerant circuit. Do not use soldering equipment or sparking or chipping tools.
- ▶ Remove the component.
- ▶ Note that removed components could continue to release refrigerant for a long time due to outgassing from the compressor oil contained in the components. This applies in particular for the compressor. Only store and transport these components in well-aerated locations.

12.4 Installing components of the refrigerant circuit

- ▶ Install the component correctly. To do this, use only soldering processes.
- ▶ Carry out a pressure test of the refrigerant circuit using nitrogen.

12.5 Filling the product with refrigerant



Danger!

Risk of death caused by fire or explosion when filling with refrigerant!

The product contains the combustible refrigerant R290. The refrigerant may mix with air to form a flammable atmosphere. There is a risk of fire and explosion.

- ▶ Only carry out the work if you are competent at handling R290 refrigerant.
- ▶ Wear suitable personal protective equipment and bring a fire extinguisher with you.
- ▶ Only use tools and units that are permitted for R290 refrigerant and are in proper working condition.

- ▶ Ensure that no air gets into the refrigerant circuit, into refrigerant-carrying tools or units, or into the refrigerant cylinder.



Caution.

Risk of material damage when using the incorrect refrigerant or contaminated refrigerant.

The product may be damaged if it is filled with the incorrect refrigerant or contaminated refrigerant.

- ▶ Use only R290 refrigerant that has not been used before and is specified as such, and the purity of which is at least 99.5%.

1. Procure the tools and units that are required for filling with refrigerant:
 - Vacuum pump
 - Refrigerant cylinder
 - Scales
2. Only use tools and units that are permitted for R290 refrigerant. Only use refrigerant cylinders that are labelled accordingly.
3. Only use hoses, couplings and valves that are leak-tight and in proper working condition. Check the tightness using a suitable gas sniffer.
4. Only use hoses that are as short as possible in order to minimise the refrigerant volume that they can hold.
5. Flush the refrigerant circuit with nitrogen.
6. Drain the refrigerant circuit.
7. Fill the refrigerant circuit with R290 refrigerant. The required fill quantity is specified on the product's data plate. Ensure in particular that the refrigerant circuit is not overfilled.
8. Check the refrigerant circuit for leak-tightness using a gas sniffer. In doing so, check all of the components and pipelines.

12.6 Completing repair and service work

- ▶ Installing the casing sections.
- ▶ Switch on the power supply and the product.
- ▶ Start up the product. Temporarily activate the heating mode.
- ▶ Check the product for leak-tightness using a gas sniffer.

13 Decommissioning

13.1 Temporarily decommissioning the product

1. Switch off all of the disconnectors to which the product is connected in the building.
2. Disconnect the product from the power supply.
3. If there is a risk of frost damage, drain the heating water from the product.

13.2 Permanently decommissioning the product



Danger!

Risk of death caused by fire or explosion when transporting units that contain refrigerant!

The product contains the combustible refrigerant R290. When transporting units without their original packaging, the refrigerant circuit may be damaged and refrigerant may be released. When mixing with air, a combustible atmosphere may form. There is a risk of fire and explosion.

- ▶ Ensure that the refrigerant is correctly removed from the product transport.

1. Switch off all of the disconnectors to which the product is connected in the building.
2. Disconnect the product from the power supply but ensure that the product is still earthed.
3. Drain the heating water from the product.
4. Remove the top casing, the front casing and the right-hand side casing.
5. Remove the refrigerant from the product. (→ Section 12.2)
6. Note that refrigerant will continue to escape even after the refrigerant circuit is completely drained due to outgassing from the compressor oil.
7. Install the right-hand side casing, the front casing and the top casing.
8. Label the product using a sticker that is visible from the outside. Note down on the sticker that the product has been decommissioned and that the refrigerant has been completely removed. Sign the sticker and specify the date.
9. Recycle the removed refrigerant in accordance with the regulations. Note that the refrigerant must be cleaned and checked before it is used again.
10. Dispose of or recycle the product and its components in accordance with the regulations.

14 Recycling and disposal

14.1 Disposing of the packaging

- ▶ Dispose of the packaging correctly.
- ▶ Observe all relevant regulations.

14.2 Disposing of the refrigerant



Danger!

Risk of death caused by fire or explosion when transporting refrigerant!

If R290 refrigerant is released during transport, a flammable atmosphere may form when it mixes with air. There is a risk of fire and explosion.

- ▶ Ensure that the refrigerant is transported correctly.

-
- ▶ Ensure that the refrigerant is disposed of by a qualified competent person.

15 Customer service

15.1 Customer service

For contact details for our customer service department, you can write to the address that is provided on the back page, or you can visit www.vaillant.co.uk.

Appendix

A Functional diagram

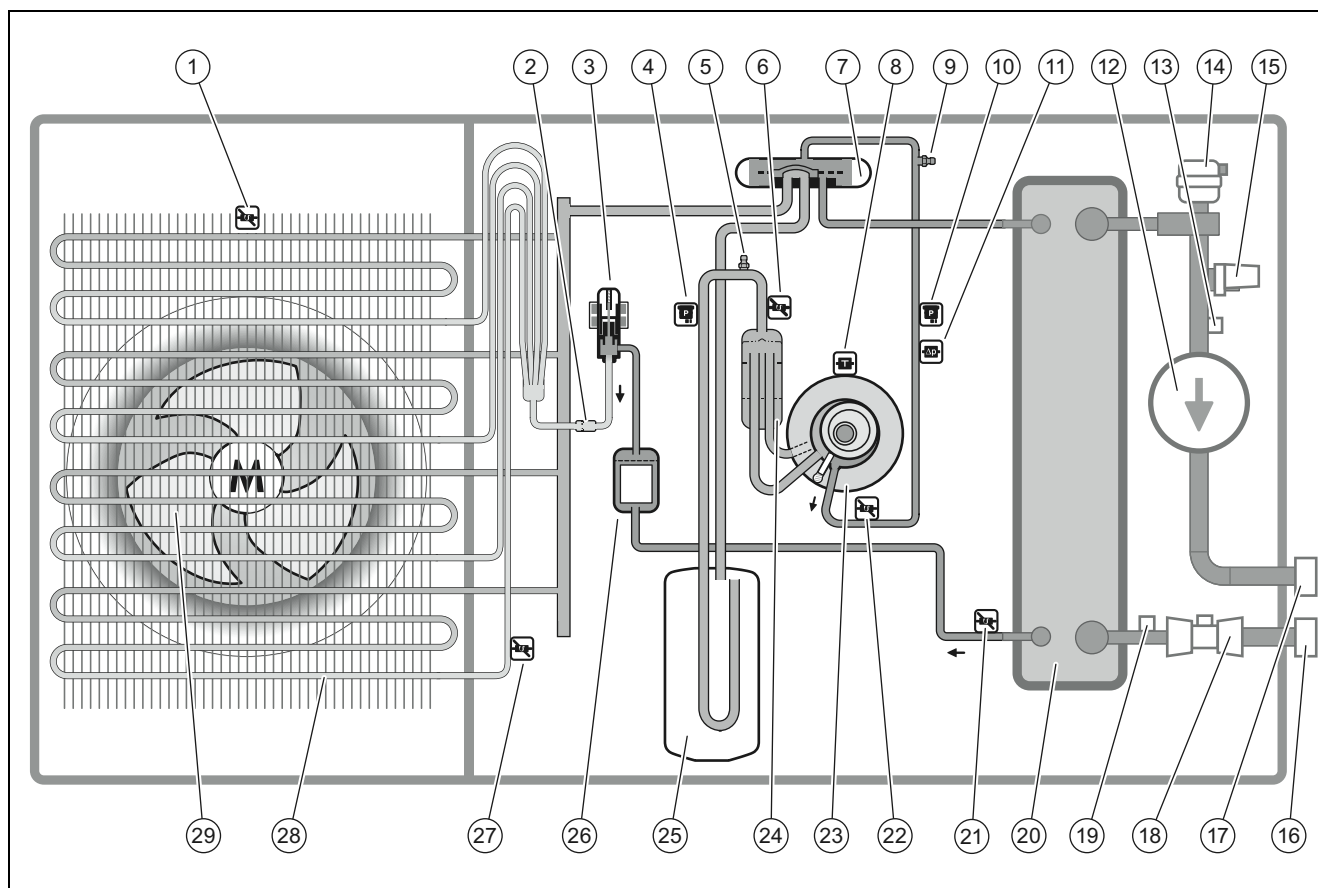

- | | | | |
|----|--|----|---|
| 1 | Temperature sensor at the air inlet | 16 | Connection for heating return |
| 2 | Filter | 17 | Connection for heating flow |
| 3 | Electronic expansion valve | 18 | Flow rate sensor |
| 4 | Pressure sensor | 19 | Temperature sensor on the heating return |
| 5 | Maintenance connection in the low-pressure area | 20 | Condenser |
| 6 | Temperature sensor upstream of the compressor | 21 | Temperature sensor downstream of the condenser |
| 7 | 4-port diverter valve | 22 | Temperature sensor downstream of the compressor |
| 8 | Temperature sensor on the compressor | 23 | Compressor |
| 9 | Maintenance connection in the high-pressure area | 24 | Refrigerant separator |
| 10 | Pressure sensor | 25 | Refrigerant buffer |
| 11 | Pressure switch | 26 | Filter/dryer |
| 12 | Heating pump | 27 | Temperature sensor at the evaporator |
| 13 | Temperature sensor on the heating flow | 28 | Evaporator |
| 14 | Automatic air vent in the heating circuit | 29 | Fan |
| 15 | Pressure sensor in the heating circuit | | |

B Safety devices

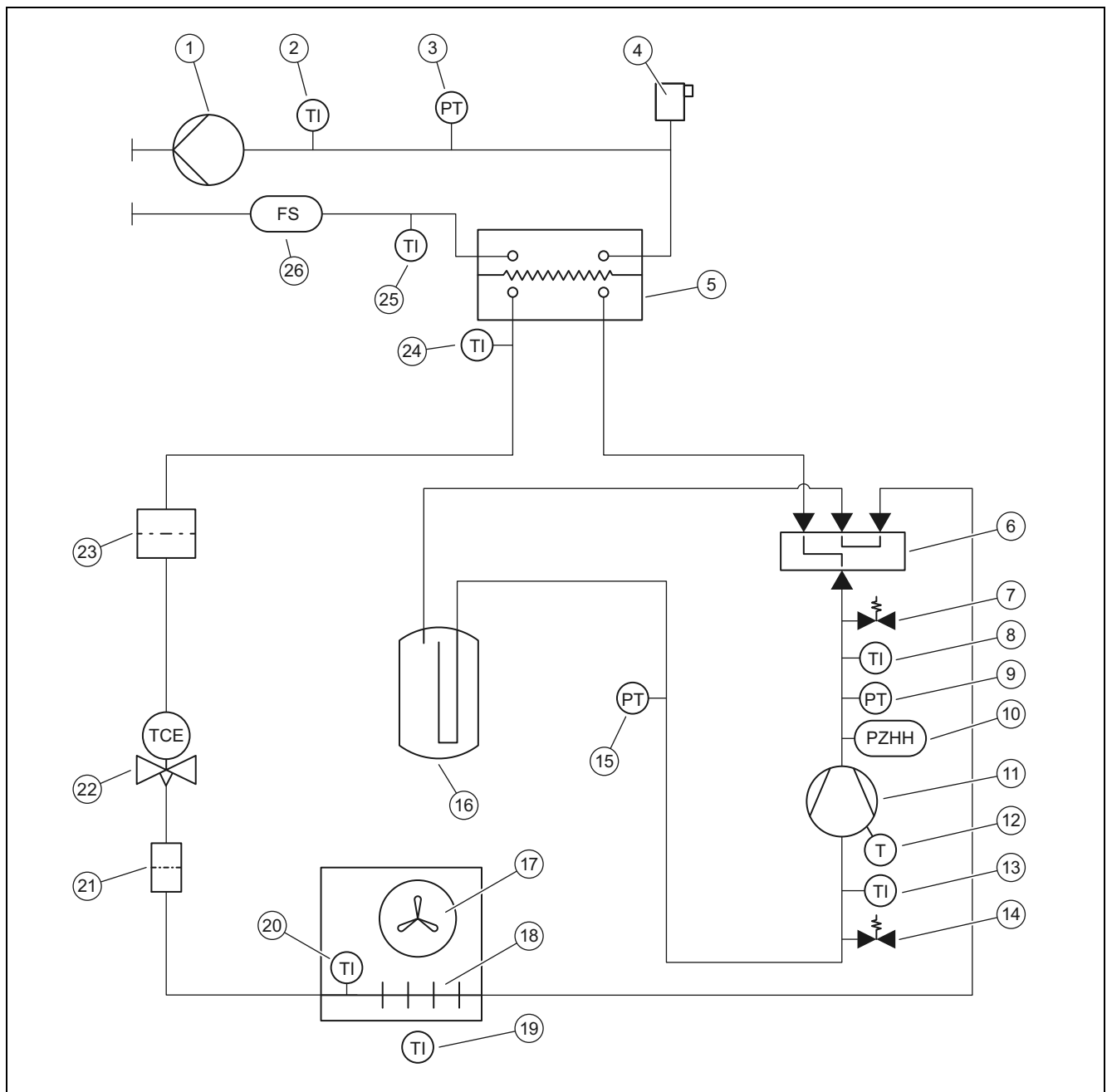

1	Heating pump	14	Maintenance connection in the low-pressure area
2	Temperature sensor on the heating flow	15	Pressure sensor in the low-pressure area
3	Pressure sensor in the heating circuit	16	Refrigerant buffer
4	Automatic air vent in the heating circuit	17	Fan
5	Condenser	18	Evaporator
6	4-port diverter valve	19	Temperature sensor at the air inlet
7	Maintenance connection in the high-pressure area	20	Temperature sensor at the evaporator
8	Temperature sensor downstream of the compressor	21	Filter
9	Pressure sensor in the high-pressure area	22	Electronic expansion valve
10	Pressure switch in the high-pressure area	23	Filter/dryer
11	Compressor with refrigerant separator	24	Temperature sensor downstream of the condenser
12	Temperature monitor at the compressor	25	Heating return temperature sensor
13	Temperature sensor upstream of the compressor	26	Flow rate sensor

C Wiring diagram

C.1 Wiring diagram, power supply, 1~/230V

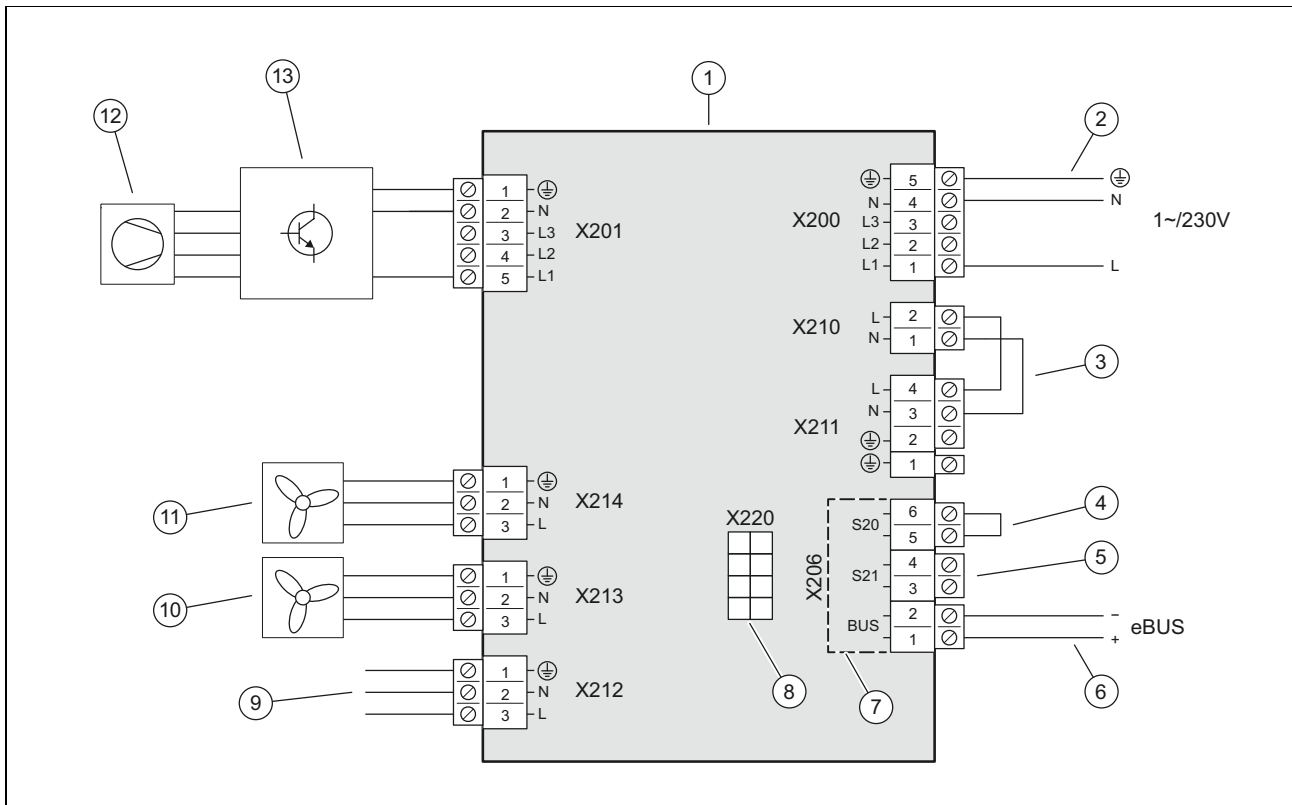

- | | | | |
|---|---|----|---|
| 1 | INSTALLER BOARD PCB | 7 | Range for the safety extra-low voltage (SELV) |
| 2 | Power supply connection | 8 | Connection to the HMU PCB, data line |
| 3 | Bridge, depending on the type of connection (energy supply company lockout) | 9 | Connection to the HMU PCB, power supply |
| 4 | Input for the limit thermostat | 10 | Power supply for fan 2, if available |
| 5 | Input S21, not used | 11 | Power supply for fan 1 |
| 6 | eBUS line connection | 12 | Compressor |
| | | 13 | INVERTER assembly |

C.2 Wiring diagram, sensors and actuators

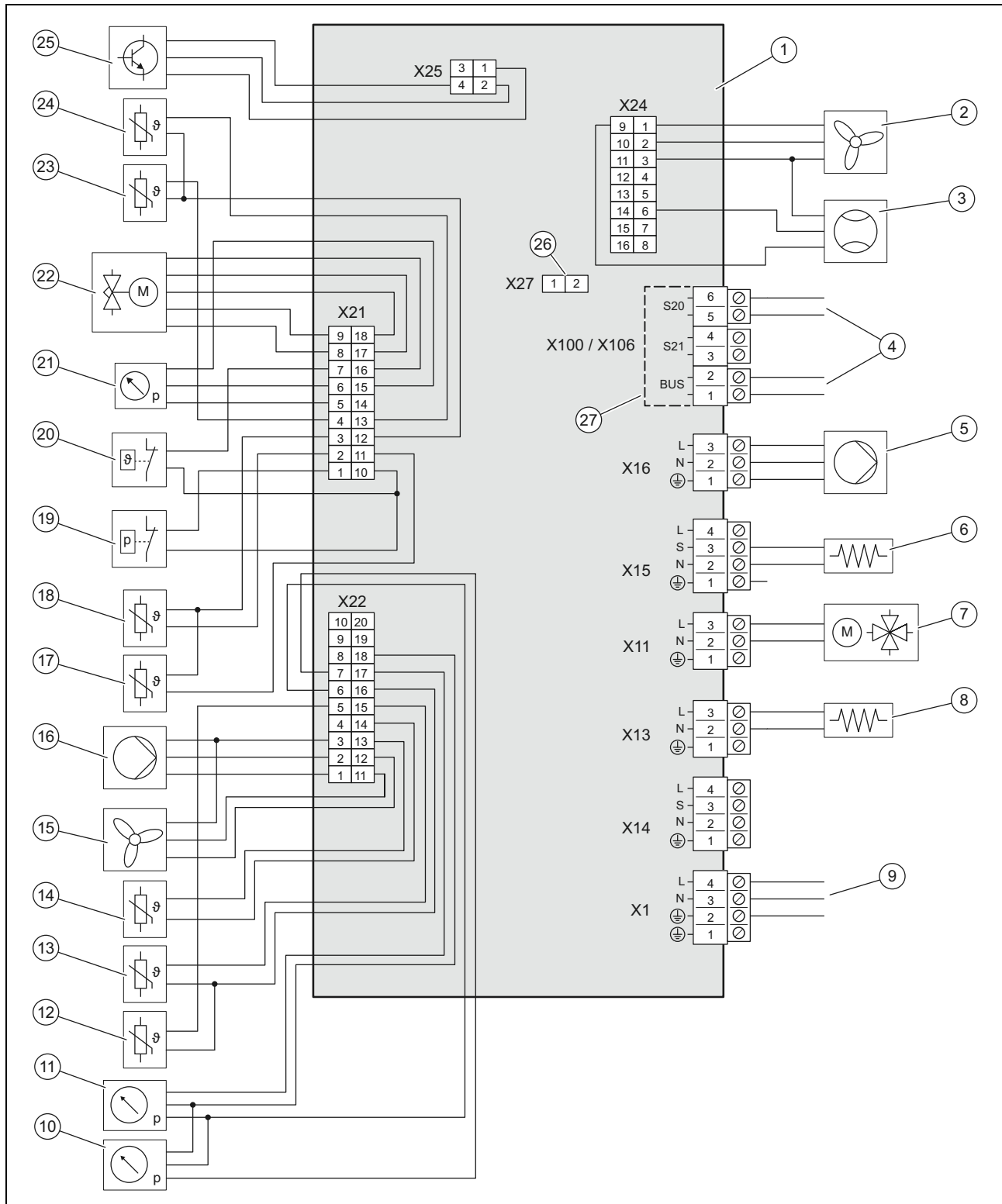

- | | | | |
|----|--|----|---|
| 1 | HMU PCB | 11 | Pressure sensor in the heating circuit |
| 2 | Actuation for fan 2, if available | 12 | Temperature sensor on the heating flow |
| 3 | Flow rate sensor | 13 | Temperature sensor on the heating return |
| 4 | Connection to the INSTALLER BOARD PCB | 14 | Temperature sensor at the air inlet |
| 5 | Heating pump power supply | 15 | Actuation for fan 1 |
| 6 | Crankcase heating | 16 | Actuation for the heating pump |
| 7 | 4-port diverter valve | 17 | Temperature sensor downstream of the compressor |
| 8 | Condensate tray heater | 18 | Temperature sensor upstream of the compressor |
| 9 | Connection to the INSTALLER BOARD PCB | 19 | Pressure switch |
| 10 | Pressure sensor in the low-pressure area | 20 | Temperature monitor |

21	Pressure sensor in the high-pressure area	25	Actuation for INVERTER assembly
22	Electronic expansion valve	26	Slot for coding resistor for cooling mode
23	Temperature sensor at the evaporator	27	Range for the safety extra-low voltage (SELV)
24	Temperature sensor downstream of the condenser		

D Inspection and maintenance work

#	Maintenance work	Interval	
1	Checking the protective zone	Annually	34
2	Cleaning the product	Annually	34
3	Closing the purging valve	During the first service	34
4	Checking the evaporator, fan and condensate discharge	Annually	35
5	Checking the refrigerant circuit	Annually	35
6	Checking the refrigerant circuit for tightness	Annually	35
7	Checking the electrical connections and electrical wires	Annually	35
8	Checking the small damping feet for wear	Annually after the first 3 years	35

E Technical data



Note

The following performance data is only applicable to new products with clean heat exchangers.

The performance data also covers noise reduction mode.

The data in accordance with EN 14825 is determined using a special test method. You can find information about this from the manufacturer of the product by stating "EN 14825 test method".

Technical data – General

	VWL 35/6 A 230V S2	VWL 55/6 A 230V S2	VWL 75/6 A 230V S2
Width	1,100 mm	1,100 mm	1,100 mm
Height	765 mm	765 mm	965 mm
Depth	450 mm	450 mm	450 mm
Weight, with packaging	132 kg	132 kg	150 kg
Weight, ready for operation	114 kg	114 kg	128 kg
Weight, ready for operation, left-/right-hand side	38 kg/76 kg	38 kg/76 kg	43 kg/85 kg
Connection, heating circuit	G 1 1/4"	G 1 1/4"	G 1 1/4"
Rated voltage	230 V (+10%/-15%), 50 Hz, 1~/N/PE	230 V (+10%/-15%), 50 Hz, 1~/N/PE	230 V (+10%/-15%), 50 Hz, 1~/N/PE
Rated power, maximum	3.40 kW	3.40 kW	3.50 kW
Rated power factor	1.0	1.0	1.0
Rated current, maximum	14.3 A	14.3 A	15.0 A
In-rush current	14.3 A	14.3 A	15.0 A
IP rating	IP 15 B	IP 15 B	IP 15 B
Fuse type	Characteristic C, slow-blow, single-pole switching	Characteristic C, slow-blow, single-pole switching	Characteristic C, slow-blow, single-pole switching
Overvoltage category	II	II	II
Fan, power consumption	40 W	40 W	40 W
Fan, quantity	1	1	1
Fan, rotational speed, maximum	620 rpm	620 rpm	620 rpm
Fan, air flow, maximum	2,300 m ³ /h	2,300 m ³ /h	2,300 m ³ /h
Heating pump, power consumption	2 to 50 W	2 to 50 W	2 to 50 W

Technical data – Heating circuit

	VWL 35/6 A 230V S2	VWL 55/6 A 230V S2	VWL 75/6 A 230V S2
Heating water temperature, minimum/maximum	20 to 75 °C	20 to 75 °C	20 to 75 °C
Basic length of the heating water pipe, maximum, between the outdoor unit and indoor unit	20 m	20 m	20 m
Operating pressure, minimum	0.05 MPa (0.50 bar)	0.05 MPa (0.50 bar)	0.05 MPa (0.50 bar)
Operating pressure, maximum	0.30 MPa (3.00 bar)	0.30 MPa (3.00 bar)	0.30 MPa (3.00 bar)
Volume flow, minimum	400 l/h	400 l/h	540 l/h
Volume flow, maximum	860 l/h	860 l/h	1,205 l/h
Water volume, in the outdoor unit	1.5 l	1.5 l	2.0 l
Water volume, in the heating circuit, minimum, thawing mode, activated/deactivated back-up heater	15 l / 40 l	15 l / 40 l	20 l / 55 l
Remaining feed pressure, hydraulic	56.0 kPa (560.0 mbar)	56.0 kPa (560.0 mbar)	44.0 kPa (440.0 mbar)

Technical data – Refrigerant circuit

	VWL 35/6 A 230V S2	VWL 55/6 A 230V S2	VWL 75/6 A 230V S2
Refrigerant, type	R290	R290	R290
Refrigerant, fill quantity	0.60 kg	0.60 kg	0.90 kg
Refrigerant, Global Warming Potential (GWP)	3	3	3
Refrigerant, CO ₂ equivalent	0.0018 t	0.0018 t	0.0027 t
Permissible operating pressure, maximum	3.15 MPa (31.50 bar)	3.15 MPa (31.50 bar)	3.15 MPa (31.50 bar)
Compressor, type	Rotary compressor	Rotary compressor	Rotary compressor
Compressor, oil type	Specific polyalkylene glycol (PAG)	Specific polyalkylene glycol (PAG)	Specific polyalkylene glycol (PAG)
Compressor, control	Electronic	Electronic	Electronic

Technical data – Power, heating mode

	VWL 35/6 A 230V S2	VWL 55/6 A 230V S2	VWL 75/6 A 230V S2
Heating output, A2/W35	2.00 kW	2.00 kW	3.10 kW
Coefficient of performance, COP, EN 14511, A2/W35	3.90	3.90	4.10
Power consumption, effective, A2/W35	0.51 kW	0.51 kW	0.76 kW
Power consumption, A2/W35	2.60 A	2.60 A	3.70 A
Heat output, minimum/maximum, A7/W35	2.10 to 5.50 kW	2.10 to 6.90 kW	3.00 to 7.40 kW
Heat output, nominal, A7/W35	3.30 kW	3.40 kW	4.60 kW
Coefficient of performance, COP, EN 14511, A7/W35	4.80	4.80	4.80
Power consumption, effective, A7/W35	0.69 kW	0.71 kW	0.96 kW
Power consumption, A7/W35	3.30 A	3.30 A	4.50 A
Heating output, A7/W45	3.10 kW	3.10 kW	4.20 kW
Coefficient of performance, COP, EN 14511, A7/W45	3.60	3.60	3.60
Power consumption, effective, A7/W45	0.86 kW	0.86 kW	1.17 kW
Power consumption, A7/W45	4.00 A	4.00 A	5.40 A
Heating output, A7/W55	4.80 kW	4.80 kW	5.00 kW
Coefficient of performance, COP, EN 14511, A7/W55	2.80	2.80	2.90
Power consumption, effective, A7/W55	1.71 kW	1.71 kW	1.72 kW

	VWL 35/6 A 230V S2	VWL 55/6 A 230V S2	VWL 75/6 A 230V S2
Power consumption, A7/W55	7.70 A	7.70 A	7.70 A
Heat output, A7/W65	4.50 kW	4.50 kW	6.30 kW
Coefficient of performance, COP, EN 14511, A7/W65	2.30	2.30	2.30
Power consumption, effective, A7/W65	1.96 kW	1.96 kW	2.74 kW
Power consumption, A7/W65	9.00 A	9.00 A	12.20 A
Heat output, A-7/W35	3.60 kW	5.40 kW	7.00 kW
Coefficient of performance, COP, EN 14511, A-7/W35	2.70	2.60	2.80
Power consumption, effective, A-7/W35	1.33 kW	2.08 kW	2.50 kW
Power consumption, A-7/W35	6.10 A	10.00 A	11.50 A

Technical data – Power, cooling mode

Validity: Product with cooling mode

	VWL 35/6 A 230V S2	VWL 55/6 A 230V S2	VWL 75/6 A 230V S2
Cooling output, A35/W18	4.50 kW	4.50 kW	6.40 kW
Energy efficiency ratio, EER, EN 14511, A35/W18	4.30	4.30	4.20
Power consumption, effective, A35/W18	1.05 kW	1.05 kW	1.52 kW
Power consumption, A35/W18	4.90 A	4.90 A	7.00 A
Cooling output, minimum/maximum, A35/W7	1.80 to 5.20 kW	1.80 to 5.20 kW	2.40 to 7.20 kW
Cooling output, A35/W7	3.40 kW	3.40 kW	4.90 kW
Energy efficiency ratio, EER, EN 14511, A35/W7	3.40	3.40	3.50
Power consumption, effective, A35/W7	1.00 kW	1.00 kW	1.40 kW
Power consumption, A35/W7	4.70 A	4.70 A	6.60 A

Technical data – Power in noise reduction mode, heating mode

	VWL 35/6 A 230V S2	VWL 55/6 A 230V S2	VWL 75/6 A 230V S2
Heat output, EN 14511, A-7/W35, 40% noise reduction mode	3.40 kW	3.40 kW	3.80 kW
Coefficient of performance, COP, EN 14511, A-7/W35, noise reduction mode 40%	3.00	3.00	3.00
Power consumption, effective, EN 14511, A-7/W35, 40% noise reduction mode	1.13 kW	1.13 kW	1.27 kW
Heat output, EN 14511, A-7/W35, 50% noise reduction mode	2.70 kW	2.70 kW	2.70 kW
Coefficient of performance, COP, EN 14511, A-7/W35, noise reduction mode 50%	2.90	2.90	2.60
Power consumption, effective, EN 14511, A-7/W35, 50% noise reduction mode	0.93 kW	0.93 kW	1.04 kW
Heat output, EN 14511, A-7/W35, 60% noise reduction mode	2.20 kW	2.20 kW	2.50 kW
Coefficient of performance, COP, EN 14511, A-7/W35, noise reduction mode 60%	2.90	2.90	2.60
Power consumption, effective, EN 14511, A-7/W35, 60% noise reduction mode	0.76 kW	0.76 kW	0.96 kW

Technical data – Noise emissions, heating mode

	VWL 35/6 A 230V S2	VWL 55/6 A 230V S2	VWL 75/6 A 230V S2
Sound power, EN 12102, EN 14511 LWA, A7/W35	51 dB(A)	51 dB(A)	53 dB(A)
Sound power, EN 12102, EN 14511 LWA, A7/W45	53 dB(A)	53 dB(A)	53 dB(A)

	VWL 35/6 A 230V S2	VWL 55/6 A 230V S2	VWL 75/6 A 230V S2
Sound power, EN 12102, EN 14511 LWA, A7/W55	54 dB(A)	54 dB(A)	55 dB(A)
Sound power, EN 12102, EN 14511 LWA, A7/W65	54 dB(A)	54 dB(A)	55 dB(A)
Sound power, EN 12102, EN 14511 LWA, A-7/W35, 40% noise reduction mode	48 dB(A)	48 dB(A)	50 dB(A)
Sound power, EN 12102, EN 14511 LWA, A-7/W35, 50% noise reduction mode	47 dB(A)	47 dB(A)	48 dB(A)
Sound power, EN 12102, EN 14511 LWA, A-7/W35, 60% noise reduction mode	46 dB(A)	46 dB(A)	46 dB(A)

Technical data – Noise emissions, cooling mode

Validity: Product with cooling mode

	VWL 35/6 A 230V S2	VWL 55/6 A 230V S2	VWL 75/6 A 230V S2
Sound power, EN 12102, EN 14511 LWA, A35/W18	53 dB(A)	53 dB(A)	55 dB(A)
Sound power, EN 12102, EN 14511 LWA, A35/W7	53 dB(A)	53 dB(A)	55 dB(A)

Benchmark Commissioning & Warranty Validation Service Record

It is a requirement that the heat pump is installed and commissioned to the manufacturers' instructions and the data fields on the commissioning checklist completed in full.

To instigate the warranty the heat pump needs to be registered with the manufacturer within one month of the installation. The warranty rests with the end-user (consumer), and they should be made aware it is ultimately their responsibility to register with the manufacturer, within the allotted time period.

It is essential that the heat pump is serviced in line with the manufacturers' recommendations, at least annually. This must be carried out by a competent, certified operative. The service details should be recorded on the Benchmark Service and Interim Heat Pump Work Record and left with the householder. Failure to comply with the manufacturers' servicing instructions and requirements will invalidate the warranty.



www.hhic.co.uk

This Commissioning Checklist is to be completed in full by the competent person who commissioned the heat pump and associated equipment as a means of demonstrating compliance with the appropriate Building Regulations and then handed to the customer to keep for future reference.

Failure to install and commission according to the manufacturers' instructions and complete this Benchmark Commissioning Checklist will invalidate the warranty. This does not affect the customer's statutory rights.

* All installations in England and Wales must be notified to Local Authority Building Control (LABC) either directly or through a Competent Persons Scheme. A Building Regulations Compliance Certificate will then be issued to the customer.

© Heating and Hotwater Industry Council (HHIC)



www.hhic.org.uk
Issue date: 20.08.2020

AIR TO WATER HEAT PUMP COMMISSIONING CHECKLIST

This Commissioning Checklist is to be completed in full by the competent person who commissioned the heat pump and associated equipment as a means of demonstrating compliance with the appropriate Building Regulations and then handed to the customer to keep for future reference.

Failure to install and commission this equipment to the manufacturer's instructions may invalidate the warranty but does not affect statutory rights.

Customer name:	Telephone number:
Address:	
Heat Pump Make and Model	
Heat Pump Serial Number	
Commissioned by (PRINT NAME):	Certified Operative Reg. No. [1]
Company name:	Telephone number:
Company address:	
	Commissioning date:
Building Regulations Notification Number (if applicable) [2]	

CONTROLS - SYSTEM AND HEAT PUMP (tick the appropriate boxes)			
Time and temperature control to heating	Room thermostat and programmer/timer		Programmable Roomstat
	Load/weather compensation		Optimum start control
Time and temperature control to hot water	Cylinder thermostat and programmer/timer		Combined with Heat pump main controls
Heating zone valves (including underfloor loops)	Fitted		Not required
Hot water zone valves	Fitted		Not required
Thermostatic radiator valves	Fitted		Not required
Heat Pump Safety Interlock [3]	Built In		Provided
Outdoor Sensor	Fitted		Not required
Automatic bypass to system	Fitted		Not required
Buffer Vessel Fitted	Yes	No	If YES Volume: Litres

ALL SYSTEMS	
The heating system has been filled and pressure tested	Yes
Expansion vessel for heating is sized, fitted & charged in accordance with manufacturer's instructions	Yes
The heat pump is fitted on a solid/stable surface capable of taking its weight	Yes
The system has been flushed and cleaned in accordance with BS7593 and heat pump manufacturer's instructions	Yes
What system cleaner was used?	
What inhibitor was used?	Quantity litres
Is the system adequately frost protected?	Yes

OUTDOOR UNIT	
Are all external pipeworks insulated?	Yes
Is the fan free from obstacles and operational?	Yes
Has suitable consideration been made for waste water discharge?	Yes

CENTRAL HEATING MODE	
Heating Flow Temperature	°C Heating Return Temperature °C

DOMESTIC HOT WATER MODE Measure and Record:			
Is the heat pump connected to a hot water cylinder?	Unvented	Vented	Thermal Store Not Connected
Hot water has been checked at all outlets	Yes	Have Thermostatic Blending Valves been fitted?	Yes Not required

ADDITIONAL SYSTEM INFORMATON					
Additional heat sources connected:	Gas Boiler	Oil Boiler	Electric Heater	Solar Thermal	Other:

ALL INSTALLATIONS	
The heating, hot water and ventilation systems complies with the appropriate Building Regulations	Yes
All electrical work complies with the appropriate Regulations	Yes
The heat pump and associated products have been installed and commissioned in accordance with the manufacturer's instructions	Yes
The operation of the heat pump and system controls have been demonstrated to the customer	Yes
The manufacturer's literature, including Benchmark Checklist and Service Record, has been explained and left with the customer	Yes

Commissioning Engineer's Signature
Customer's Signature
(To confirm satisfactory demonstration and receipt of manufacturer's literature)

Notes: [1] Installers should be members of an appropriate Competent Persons Scheme. [2] All installations in England and Wales must be notified to Local Area Building Control (LABC) either directly or through a Competent Persons Scheme. A Building Regulations Compliance Certificate will then be issued to the customer. [3] May be required for systems covered by G3 Regulations



SERVICE RECORD

It is recommended that your heating system is serviced regularly and that the appropriate Service Interval Record is completed.

Service Provider

Before completing the appropriate Service Record below, please ensure you have carried out the service as described in the manufacturer's instructions. Always use the manufacturer's specified spare part when replacing controls.

SERVICE 01	Date:	SERVICE 02	Date:
Engineer name:		Engineer name:	
Company name:		Company name:	
Telephone No:		Telephone No:	
Operative ID No:		Operative ID No:	
Comments:		Comments:	
Signature		Signature	
SERVICE 03	Date:	SERVICE 04	Date:
Engineer name:		Engineer name:	
Company name:		Company name:	
Telephone No:		Telephone No:	
Operative ID No:		Operative ID No:	
Comments:		Comments:	
Signature		Signature	
SERVICE 05	Date:	SERVICE 06	Date:
Engineer name:		Engineer name:	
Company name:		Company name:	
Telephone No:		Telephone No:	
Operative ID No:		Operative ID No:	
Comments:		Comments:	
Signature		Signature	
SERVICE 07	Date:	SERVICE 08	Date:
Engineer name:		Engineer name:	
Company name:		Company name:	
Telephone No:		Telephone No:	
Operative ID No:		Operative ID No:	
Comments:		Comments:	
Signature		Signature	
SERVICE 09	Date:	SERVICE 10	Date:
Engineer name:		Engineer name:	
Company name:		Company name:	
Telephone No:		Telephone No:	
Operative ID No:		Operative ID No:	
Comments:		Comments:	
Signature		Signature	

Index

A	
Air inlet grille	28
Air outlet grille.....	27
Application limit	18
Assembly and component	16–17
B	
Basic diagram.....	14
C	
Casing section.....	27, 34
CE marking.....	18
Competent person.....	13
Condensate discharge	21–22, 35
Cooling mode	15
D	
Data plate	17
Dimension	22–23
E	
Electrical partition	30
Electricity	13
Energy supply company lockout.....	30
Evaporator.....	35
F	
Fan	35
Foundation	25
Functionality	15
H	
Heat pump system	15
I	
Installation site.....	23
Installation type	28
Intended use.....	13
L	
Leak-tightness	35
Limit thermostat.....	32
M	
Minimum circulation water volume	28
P	
Power supply.....	31
Pre-installation jig.....	28–29
Protective zone.....	19
Purging valve.....	34
Q	
Qualification.....	13
Quality of the mains voltage	30
R	
Refrigerant.....	36
Disposal	38
Refrigerant circuit	35
Regulations	14
Remaining feed pressure	33
S	
Safety device.....	14, 19, 40
Scope of delivery.....	22
Spare parts.....	34
Swimming pool	29
T	
Thawing mode.....	19
Transport	22
Treating the heating water.....	32
Type of installation	23
V	
Voltage	13

W

Warning sticker.....	18
----------------------	----

Supplier

Vaillant Ltd.

Nottingham Road ■ Belper ■ Derbyshire ■ DE56 1JT

Telephone 0330 100 3143

info@vaillant.co.uk ■ www.vaillant.co.uk



0020330791_01

Publisher/manufacturer

Vaillant GmbH

Berghauser Str. 40 ■ D-42859 Remscheid

Tel. +49 2191 18 0 ■ Fax +49 2191 18 2810

info@vaillant.de ■ www.vaillant.de

© These instructions, or parts thereof, are protected by copyright and may be reproduced or distributed only with the manufacturer's written consent.

Subject to technical modifications.