

For the operator

## Operating instructions



**aroTHERM**

VWL ../2 A 230 V

**GB**

**Publisher/manufacture**

**Vaillant GmbH**

Berghauser Str. 40 ■ D-42859 Remscheid  
Tel. +49 21 91 18-0 ■ Fax +49 21 91 18-28 10  
info@vaillant.de ■ www.vaillant.de



# Contents

## Contents

<b>1</b>	<b>Safety</b> .....	<b>3</b>	5.4	Setting the target feed temperature in heating mode.....	15
1.1	Action-related warnings .....	3	5.5	Setting a room thermostat or weather compensator .....	15
1.2	General safety information.....	3	5.6	Checks and maintenance carried out by the operator.....	15
1.3	Intended use .....	7	5.7	Having the product temporarily decommissioned.....	16
1.4	CE label .....	8	<b>6</b>	<b>Troubleshooting</b> .....	<b>16</b>
<b>2</b>	<b>Notes on the documentation</b> .....	<b>9</b>	6.1	Reading the fault message .....	16
2.1	Observing other applicable documents .....	9	6.2	Detecting and rectifying faults.....	17
2.2	Storing documents.....	9	<b>7</b>	<b>Decommissioning</b> .....	<b>18</b>
2.3	Applicability of the instructions.....	9	7.1	Having the product permanently decommissioned.....	18
<b>3</b>	<b>Product description</b> .....	<b>10</b>	<b>8</b>	<b>Recycling and disposal</b> .....	<b>18</b>
3.1	Design of the heat pump system .....	10	8.1	Recycling and disposal .....	18
3.2	Type designation and serial number.....	11	8.2	Arranging disposal of coolant .....	18
3.3	Overview of the operator control elements of the VWZ AI heat pump control module .....	11	<b>9</b>	<b>Guarantee and customer service</b> .....	<b>18</b>
3.4	Digital Information and Analysis System (DIA) .....	11	9.1	Guarantee.....	18
<b>4</b>	<b>Operation</b> .....	<b>12</b>	9.2	Customer service.....	19
4.1	Operating concept .....	12			
4.2	Basic display.....	12			
4.3	Operating levels.....	13			
4.4	Design of the menu.....	13			
4.5	Live Monitor (status codes).....	13			
4.6	Displaying the building circuit pressure.....	14			
4.7	Reading the operating statistics .....	14			
4.8	Displaying contact data.....	14			
4.9	Displaying the serial number and article number .....	14			
4.10	Setting the display contrast.....	14			
4.11	Setting the language.....	14			
<b>5</b>	<b>Operation</b> .....	<b>14</b>			
5.1	Switching the product on/off .....	14			
5.2	Operating noises.....	15			
5.3	Activating frost protection .....	15			

## 1 Safety

### 1.1 Action-related warnings

#### Classification of action-related warnings

The action-related warnings are classified in accordance with the severity of the possible danger using the following warning signs and signal words:

#### Warning symbols and signal words



#### **Danger!**

Imminent danger to life or risk of severe personal injury



#### **Danger!**

Risk of death from electric shock



#### **Warning.**

Risk of minor personal injury



#### **Caution.**

Risk of material or environmental damage

### 1.2 General safety information

#### 1.2.1 Danger caused by improper operation

Improper operation may present a danger to you and others, and cause material damage.

- ▶ Carefully read the enclosed instructions and all other applicable documents, particu-

larly the "Safety" section and the warnings.

#### 1.2.2 Risk of death due to explosions and scaldings from brine fluid

The brine fluid ethylene and propylene glycol is extremely flammable, both as liquid and steam. A potentially explosive combination of steam/air may form.

- ▶ Keep away from heat, sparks, naked flames and hot surfaces.
- ▶ Prevent steam/air mixtures from forming. Keep brine fluid vessels closed.
- ▶ Observe the safety data sheet that accompanies the brine fluid.

#### 1.2.3 Danger due to improper use

There is a risk of injury or death to the user or others, or of damage to the product and other property in the event of improper use or use for which it is not intended.

Only use the product in accordance with the provisions.

# 1 Safety

## 1.2.4 Preventing the risk of injury from corrosive brine fluid

The brine fluid ethylene glycol is harmful to health.

- ▶ Avoid contact with the skin and eyes.
- ▶ Always wear gloves and protective goggles.
- ▶ Do not inhale or swallow.
- ▶ Observe the safety data sheet that accompanies the brine fluid.

## 1.2.5 Preventing the risk of injury due to scalding from hot and cold components

Particularly in the coolant circuit, the components of the heat pump can reach high temperatures or extremely low temperatures.

- ▶ Do not touch any uninsulated pipelines in any part of the heating installation.
- ▶ Do not remove any casing sections.

## 1.2.6 Risk of being scalded by hot drinking water

There is a risk of scalding at the hot water draw-off points if the hot water temperatures are greater than 50 °C. Young children and elderly persons are

particularly at risk, even at lower temperatures.

- ▶ Select the temperature so that nobody is at risk.

## 1.2.7 Risk of death due to lack of safety devices

A lack of safety devices (e.g. expansion relief valve, expansion vessel) can lead to potentially fatal scalding and other injuries, e.g. due to explosions.

- ▶ Have your competent person check that all required isolator devices are present in your heating installation.

## 1.2.8 Preventing the risk of injury from freezing as a result of touching coolant

The product is delivered with an operational filling of R410A coolant. This is a chlorine-free coolant which does not affect the Earth's ozone layer. R410A is neither a fire hazard nor an explosion risk. Escaping coolant may cause freezing if the exit point is touched.

- ▶ If coolant escapes, do not touch any components of the product.
- ▶ Do not inhale any steam or gases that escape from the coolant circuit as a result of leaks.



- ▶ Avoid skin or eye contact with the coolant.
- ▶ In the event of skin or eye contact with the coolant, seek medical advice.

### **1.2.9 Danger due to changes to the product environment**

There is a risk of injury or death to the user or others, or of damage to the product and other property, in the event of changes to the product environment.

Changes must not be made to the following equipment:

- The heat pump
- The heat pump environment
- The drain line and expansion relief valve for the heating water
- The water and electricity supply lines
- The heat pump's condensate drain pipework
- The structural conditions that may affect the operational safety of the product.

### **1.2.10 Risk of injury and material damage due to incorrect maintenance or repairs**

As a result of unauthorised interference or tampering with the product or parts of the system,

the operational safety of the product can no longer be ensured and the guarantee therefore becomes void.

- ▶ Never interfere or tamper with the product or other parts of the system.
- ▶ Never try to carry out maintenance work or repairs on the product yourself.
- ▶ Do not damage or remove any seals on components. Only qualified competent persons and factory service personnel are authorised to make modifications to sealed components.
- ▶ Have inspection and maintenance work carried out by a competent person.

### **1.2.11 Frost damage due to an unsuitable installation site**

Frost poses a risk of damage to the product and the whole heating installation.

- ▶ You should therefore ensure that the heating installation always remains in operation during freezing conditions and that all rooms are sufficiently heated.

Even if rooms, or the whole dwelling, are not in use for certain periods, the heating must remain in operation.



# 1 Safety

Frost protection and monitoring devices are only active while the product is connected to the power supply. The product must be connected to the power supply.

## 1.2.12 Frost damage caused by insufficient room temperature

If the room temperature is set too low in individual rooms, it cannot be ruled out that sections of the heating installation might be damaged by frost.

- ▶ If you are going to be away during a cold period, ensure that the heating installation remains in operation and that the rooms are sufficiently heated.
- ▶ You must observe the frost protection instructions.

## 1.2.13 Frost damage caused by a power cut

During installation, your competent person connected your product to the power mains. If the power supply is cut, it is possible that parts of the heating installation may become damaged by frost. If you want to use an emergency power generator to maintain the operational readiness of the product

during a power cut, note the following:

- ▶ Contact your competent person for advice on installing an emergency power generator.
- ▶ Ensure that the technical values of this generator (frequency, voltage, earthing) match those of the power mains.

## 1.2.14 Malfunction caused by incorrect system pressure

To avoid operating the system with too little water and thus prevent resulting damage, note the following:

- ▶ Check the system pressure of the heating installation at regular intervals.
- ▶ You must observe the system pressure instructions.

## 1.2.15 Malfunction due to incorrect power supply

The power supply must remain within the specified limits so that the product does not malfunction:

- 1 phase: 230 V (+10/-15%)  
~50 Hz
- 3 phases: 400 V (+10/-15%) 3  
N ~50 Hz

### **1.2.16 Avoid environmental damage caused by escaping coolant**

The product contains R410A coolant. The coolant must not be allowed to escape into the atmosphere. R410A is a fluorinated greenhouse gas covered by the Kyoto Protocol, with a GWP of 1725 (GWP = Global Warming Potential). If this gas escapes into the atmosphere, its impact is 1725 times greater than the natural greenhouse gas CO<sub>2</sub>.

Before the product is disposed of, the coolant that is contained in it must be completely drained into a suitable vessel so that it can then be recycled or disposed of in accordance with regulations.

- ▶ Ensure that only officially certified competent persons with appropriate protective equipment carry out maintenance work on the coolant circuit or access it.
- ▶ Arrange for the coolant contained in the product to be recycled or disposed of by certified competent persons in accordance with regulations.

## **1.3 Intended use**

### **1.3.1 State-of-the-art technology**

The Vaillant **aroTHERM** heat pump systems are constructed using state-of-the-art technology in accordance with the recognised safety rules and regulations. However, there is a risk of injury or death to the user or others, or of damage to the product and other property, in the event of improper use or use for which it is not intended.

### **1.3.2 User qualification**

This product can be used by children aged from 8 years and above and persons with reduced physical, sensory or mental capabilities or lack of experience and knowledge if they have been given supervision or instruction concerning use of the product in a safe way and understand the hazards involved. Children must not play with the product. Cleaning and user maintenance work must not be carried out by children unless they are supervised.

### **1.3.3 Intended use**

The Vaillant **aroTHERM** heat pump is designed for use as a heat generator for closed heating installations. Operation of



## 1 Safety

the pump outside the application limits results in the heat pump being switched off by the internal control and safety devices.

### 1.3.4 Improper use

Any use which is not explicitly mentioned in the section "Intended use" is deemed improper.

Any other or additional use does not comply with the intended use. Any direct commercial or industrial use is also deemed to be improper.

### 1.3.5 Observing other applicable documents

Intended use also includes the observance of accompanying operating, installation and servicing instructions for Vaillant products as well as for other parts and components of the system.

### 1.3.6 Liability and secondary clauses

The manufacturer/supplier is not liable for any claims or damage resulting from improper use. The user alone bears the risk.

#### **Caution.**

Improper use of any kind is prohibited.

## 1.4 CE label



The CE label shows that the products comply with the basic requirements of the applicable directives as stated on the identification plate.

The declaration of conformity can be viewed at the manufacturer's site.





## 2 Notes on the documentation

### 2.1 Observing other applicable documents

- ▶ You must observe all operating instructions enclosed with the system components.

### 2.2 Storing documents

- ▶ Keep this manual and all other applicable documents safe for future use.

### 2.3 Applicability of the instructions

These instructions apply only for the following heat pumps, hereinafter referred to as the "product":

Type designation	Art. no.
aroTHERM VWL 55/2 A 230 V	0010014566
aroTHERM VWL 85/2 A 230 V	0010011971
aroTHERM VWL 115/2 A 230 V	0010011972
aroTHERM VWL 155/2 A 230 V	0010014567

The product's article number is part of the serial number (→ Page 11).

## 3 Product description

### 3 Product description

#### 3.1 Design of the heat pump system

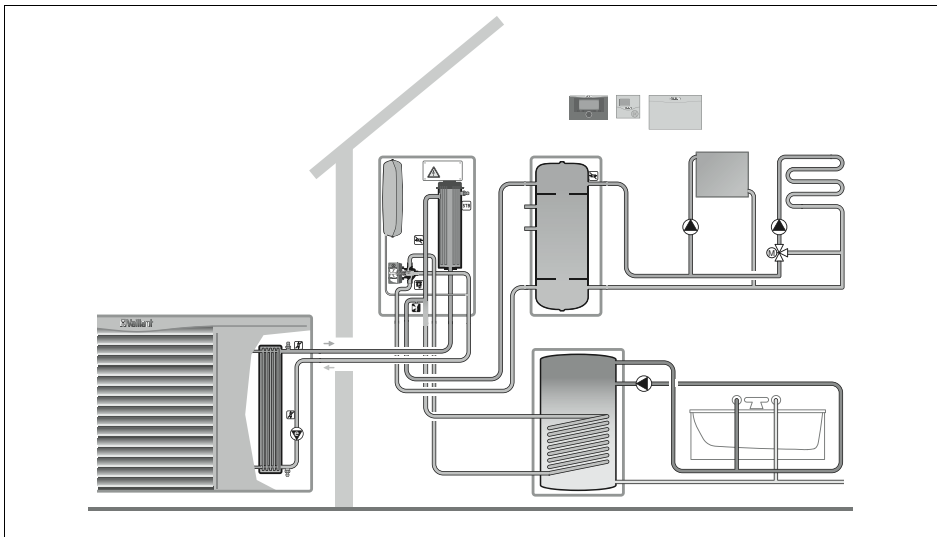

The heat pump system consists of the following components:

- Heat pump
- VWZ AI heat pump control module
- Additional hydraulic components, if required
- System controller

The heat pump can be operated by the VWZ AI heat pump control module. The extended operation of the heat pump is carried out by the system controller.

## Product description 3

### 3.2 Type designation and serial number

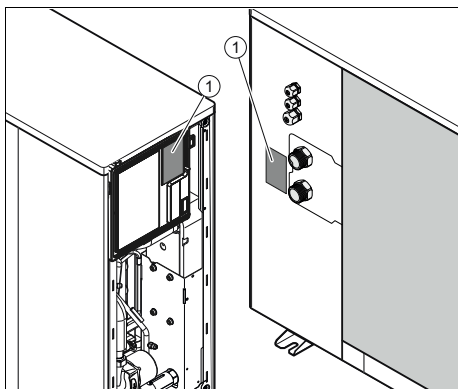

The type designation and serial number are on the identification plate (1).

### 3.3 Overview of the operator control elements of the VWZ AI heat pump control module

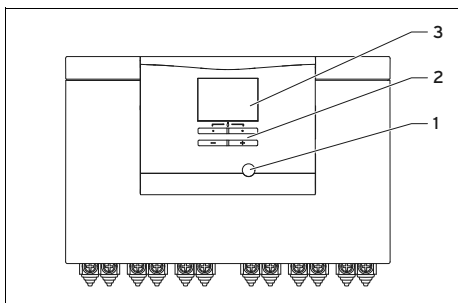

- |  |  |
|--|--|
| <p>1 Fault clearance key<br/>The fault clearance key is used to reset the heat pump faults and heat pump accessory faults.</p> | <p>2 Operating buttons<br/>3 Display</p> |
|--|--|

### 3.4 Digital Information and Analysis System (DIA)

The product is equipped with a Digital Information and Analysis System (DIA system). This system provides information on the operating status of the product and helps you to rectify faults.

The display lights up

- if you switch on the product or
- if you press a button in the DIA system while the product is switched on. At first, pressing this button does not trigger any other function.

The light goes out after one minute if you do not press any button.

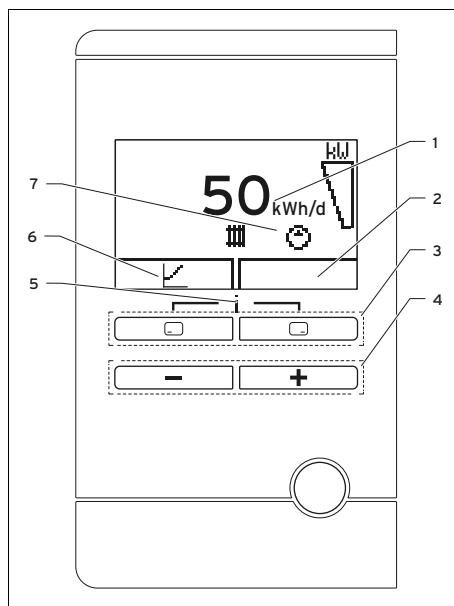

- |  |  |
|--|--|
| <p>1 Display of the daily energy yield<br/>2 Display of the current configuration of the right-hand selection button</p> | <p>3 Left- and right-hand selection buttons<br/>4 Minus and plus buttons</p> |
|--|--|

## 4 Operation

- 5 Access to the menu for additional information
- 6 Display of the current configuration of the left-hand selection button
- 7 Display of the symbols for the active operating status of the pumps

Heating mode: 

- The symbol lights up permanently: Heat requirement is present
- The symbol is not visible: Heating mode is not active

Cooling mode: 

- The symbol lights up permanently: Cooling requirement is present
- The symbol is not visible: Cooling mode is not active

Current power: 

- The display shows the current heat pump output

Fault:  F.XXX

- Fault in the heat pump. Appears instead of the basic display; a plain text display explains the displayed fault code.

## 4 Operation

### 4.1 Operating concept

You can operate the product using the selection buttons and the plus/minus buttons. Both selection buttons have a soft key function, i.e. their function can change.



By pressing  :

- You can cancel the change to a set value or the activation of an operating mode
- You can go one selection level higher in the menu.

By pressing  :

- You can confirm a set value or the activation of an operating mode

- You can go one selection level lower in the menu.

By pressing  and  at the same time:

- You can navigate to the menu.

By pressing  or :

- You can scroll through the entries in the menu
- You can increase or decrease a selected set value.

Adjustable values are always displayed as flashing.

You must always confirm a change to a value. Only then is the new setting saved.

You can press  to cancel a procedure.

If you do not press any buttons for longer 15 minutes, the display returns to the basic display.

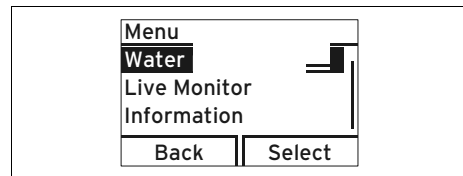

A highlighted object is indicated in the display as light text on a dark background.

### 4.2 Basic display

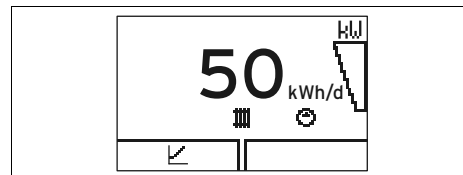

The displays shows the basic display with the current status of the product. If you press a selection button, the activated function is displayed in the display.

You can switch back to the basic display by:

- Pressing  and thus exiting the selection levels
- Not pressing any button for longer than 15 minutes.

As soon as a fault message is present, the basic displays switches to the fault message.

### 4.3 Operating levels

The product has two operating levels.

The operating level for the operator shows the most important information and offers set-up options which do not require any special prior knowledge.

The operating level for the competent person is reserved for the competent person only and is protected by a code. In this level, the competent person can set system-specific parameters.

### 4.4 Design of the menu

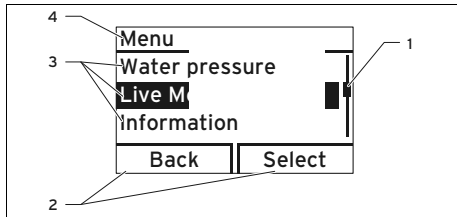

- 1 Scroll bar (only appears if there are more list entries than can be shown at once on the display)
- 2 Current configuration of the right- and left-hand selection buttons (soft key function)
- 3 Selection level list entries
- 4 Name of the selection level

The menu is split into two selection levels.



#### Note

Path details at the start of a section specify how to access this function, e.g. **Menu → Information → Contact data.**

#### 4.4.1 Operator level overview

Setting level	Unit
Menu → Yield indicator→	

Setting level	Unit
Heating	
Cooling	
Menu → Live Monitor	
Heating: Compressor switch-off	
Building circuit Pressure	
Target flow temp.	
Current flow temp.	
Compressor Modulation	
Air inlet temperature	
Cooling output	
Menu → Information	
Contact details	
Serial number	
Device specific number	
Operating hrs. Total	
Operating hrs. Heating	
Operating hrs. Cooling	
Menu → Basic settings →	
Language	15
Display contrast	
Menu → Resets →	
No sub-items Available	

### 4.5 Live Monitor (status codes)

#### Menu → Live Monitor

You can use the Live Monitor to display the current status of the product.

## 5 Operation

### 4.6 Displaying the building circuit pressure

**Menu** → **Live Monitor** → **Building circuit pressure**

- You can display the current filling pressure of the heating installation in digital form.

### 4.7 Reading the operating statistics

**Menu** → **Information** → **Heating op. hours**

**Menu** → **Information** → **Cooling op. hours**

**Menu** → **Information** → **Total operating hours**

In each case, you can display the operating hours for the heating mode, the cooling mode and the overall operation.

### 4.8 Displaying contact data

**Menu** → **Information** → **Contact details**

If your competent person has entered their telephone number during the installation, you can read this data under **Contact data**.

### 4.9 Displaying the serial number and article number

**Menu** → **Information** → **Serial number**

- The product's serial number is displayed.
- The article number is found in the second line of the serial number.







### 4.10 Setting the display contrast

**Menu** → **Basic setting** → **Display contrast**

- You can use this function to adjust the display contrast to suit your needs.

### 4.11 Setting the language

If you want to set another language:

- ▶ Press and hold  and  **at the same time**.
- ▶ Also press the fault clearance key for a short time.
- ▶ **Press and hold**  and  until the display shows the language setting.
- ▶ Select the required language by pressing  or .
- ▶ Press (OK) to confirm your selection.
- ▶ Once you have set the correct language, press (OK) again to confirm this.

## 5 Operation

### 5.1 Switching the product on/off

- ▶ Use a partition with a contact opening of at least 3 mm (e.g. fuses or power switches) to de-energise the product.

## 5.2 Operating noises

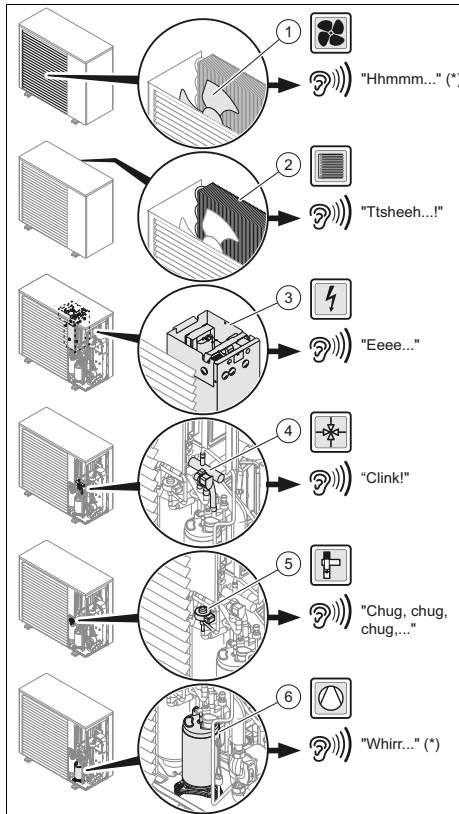

\* Permanent operating noises

The noises listed do not constitute a fault with the heat pump.

In various operating modes, the noises come from the heat pump (Start, Thawing, Stop).

## 5.3 Activating frost protection

- ▶ To prevent the product from freezing, ensure that the product is switched on.

## 5.4 Setting the target feed temperature in heating mode

The actual target flow temperature is automatically determined by the system controller (you can find further information about this in the operating instructions for the system controller).

## 5.5 Setting a room thermostat or weather compensator

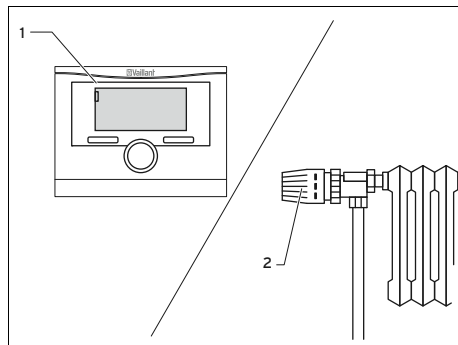

- ▶ Set the room thermostat or the weather compensator (1) and thermostatic radiator valves (2) as specified in the relevant instructions for these accessories.

## 5.6 Checks and maintenance carried out by the operator

The product switches off if the filling pressure in the heating installation falls below 0.05 MPa (0.5 bar).

- ▶ Top up with water.

### 5.6.1 Cleaning the product

1. Switch the product off before you clean it.
2. Clean the product's casing with a damp cloth and a little soap. Never use scouring or cleaning agents which could damage the casing or the operator control elements.

## 6 Troubleshooting

3. Do not clean the product with a high-pressure cleaner.
4. At regular intervals, check that no branches or leaves have gathered around the product.

### 5.6.2 Checking the maintenance plan



#### **Danger!**

#### **Risk of injury and risk of material damage due to neglected or incorrect maintenance and repairs.**

Neglected or incorrect maintenance work or repairs may lead to personal injury or damage to the product.

- ▶ Never attempt to carry out maintenance work or repairs on the product.
- ▶ Employ an authorised heating specialist company to complete such work. We recommend making a maintenance agreement.

1. Regular inspection/maintenance of your product by a competent person is a prerequisite for ensuring that the system is constantly ready and safe for operation, reliable and has a long service life.



#### **Note**

Failure to carry out maintenance and repair work, and non-compliance with the specified inspection, maintenance and replacement intervals, leads to a loss of potential guarantee claims. We recommend making a maintenance agreement with a competent person.

2. The maintenance intervals depend on the local conditions and the use of the product.
3. Have parts that are relevant to the function and safety replaced by a competent person.

### 5.7 Having the product temporarily decommissioned

- ▶ If, during long periods of absence, the power supply to the dwelling and to the product is interrupted, have the heating system drained by your competent person or have it sufficiently protected against frost.

## 6 Troubleshooting

### 6.1 Reading the fault message

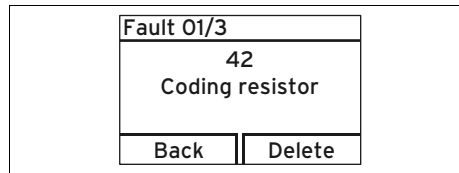

Fault messages have priority over all other displays and are shown instead of the basic display. If several faults occur at the same time, these are each displayed alternately for two seconds each.

- ▶ If your product displays a fault message, contact a competent person.
- ▶ To find out more information about the status of your product, call up the "Live Monitor" (→ Page 13).



## 6.2 Detecting and rectifying faults

This section shows all of the fault messages that can be rectified without seeking help from the competent person in order to start up the product again.

Remedy (→ Page 17)

- If the product still does not function after the fault has been rectified, contact your competent person.

Fault	Cause	Remedy
The product no longer works.	The power supply has been disconnected	Ensure that there has not been a power cut and that the product is correctly connected to the power supply. When the power supply is re-established, the product automatically starts up. If a fault is still present, contact your competent person.
Noises (hissing, knocking, humming)	If the heating demand stops, this may lead to bubbling and whistling noises. These noises are caused by the coolant. When the product starts up or stops, this may lead to creaking noises. These noises are caused by the casing as it expands or contracts when the temperature changes. If the product is functioning, this may lead to humming noises. These noises are caused by the compressor when the product is in heating mode.	
The product releases steam.	In winter and during the thawing procedure, steam may escape from the product. (The heat of the product melts the ice that has formed.)	
Other faults		Consult your competent person.

## 7 Decommissioning

### 7 Decommissioning

#### 7.1 Having the product permanently decommissioned

- ▶ Have a competent person permanently decommission the product.

## 8 Recycling and disposal

### 8.1 Recycling and disposal

- ▶ The competent person who installed your product is responsible for the disposal of the packaging.



If the product is identified with this symbol:

- ▶ In this case, do not dispose of the product with the household waste.
- ▶ Instead, hand in the product to a collection centre for old electrical or electronic appliances.



If the product contains batteries that are marked with this symbol, these batteries may contain substances that are hazardous to human health and the environment.

- ▶ In this case, dispose of the batteries at a collection point for batteries.

### 8.2 Arranging disposal of coolant

The Vaillant **aroTHERM** heat pump is filled with the coolant R410A.

- ▶ Coolant must only be disposed of by qualified competent persons.
- ▶ Observe the general safety information.

## 9 Guarantee and customer service

### 9.1 Guarantee

Vaillant provides a full parts and labour guarantee for this appliance for the duration as shown on the enclosed registration card which must be fully completed and returned within 30 days of installation. All appliances must be installed by a suitably competent person fully conversant and in accordance with all current regulations applicable to the appliance type installation. In the case of gas appliances the Gas Safety (Installation and Use) Regulations 1998, and the manufacturer's instructions. In the UK competent persons approved at the time by the Health and Safety Executive undertake the work in compliance with safe and satisfactory standards. Installers should also be fully conversant with and competent with all necessary electrical and building regulations that may apply to the installation.

In addition all unvented domestic hot water cylinders must be installed by a competent person to the prevailing building regulations at the time of installation (G3). All appliances shall be fully commissioned in accordance with our installation manual and Benchmark commissioning check list (this will be included within the installation manual). These must be signed and given to the user for safe keeping during the hand over process. Installers should also at this time advise the user of the annual servicing requirements and advise of appropriate service agreement.

Terms and conditions do apply to the guarantee, details of which can be found on the registration card included with this appliance. In order to qualify for guarantee after one year the appliance must be serviced in accordance with our installation manual servicing instructions. The benchmark service history should be completed. Note -

## Guarantee and customer service 9

all costs associated with this service are excluded from this guarantee.

Failure to install and commission this appliance in compliance with the manufacturer's instructions will invalidate the guarantee (this does not affect the customer's statutory rights).

### **9.2 Customer service**

To ensure efficient and reliable operation of your boiler it is recommended that regular servicing is carried out by your service provider.

0020151761\_04 || 20.11.2015

**Vaillant Ltd.**

Nottingham Road || Belper || Derbyshire || DE56 1JT

Telephone 0330 100 3461

info@vaillant.co.uk || www.vaillant.co.uk

© These instructions, or parts thereof, are protected by copyright and may be reproduced or distributed only with the manufacturer's written consent.